

SPECS: AST-120/OST-120

CAPACITY.....120 GALLONS (16.4 CU. FT.)

WEIGHT.....329 LBS. (148.05 kg)

CODE.....ASME Sec. VIII Div 1

DIMENSIONS:

Diameter.....24" (60.96 cm)

Height (w/base).....Approx. 75"(190.5 cm)

PRESSURE RATING.....200 PSI (TESTED AT 260 PSI)

FITTING SIZES.....F1=1" NPT

F2=2" NPT

F3=1/2" NPT

F4=2" NPT

F5=1/4" NPT

F6=1-1/2" NPT

F7=1" NPT

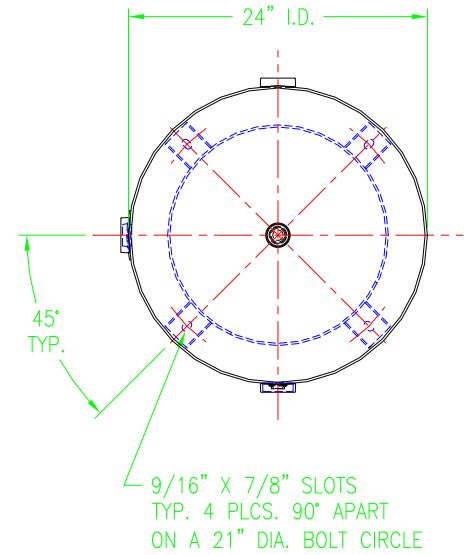
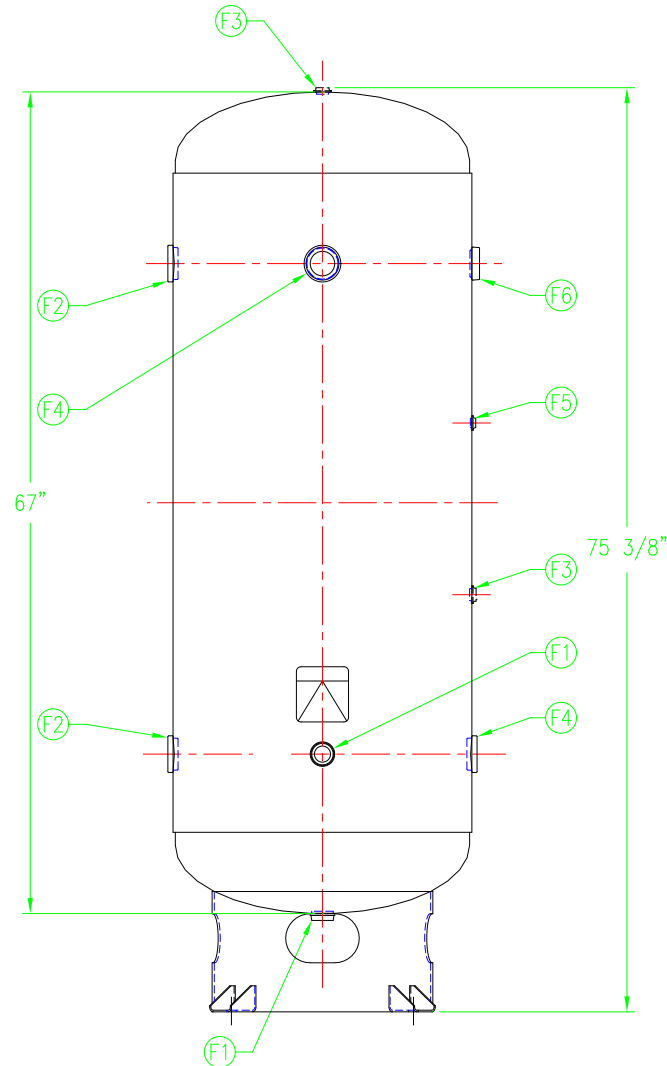

REVISIONS

REV	DESCRIPTION	DATE	CHK	ECN #

**OGSI**  
 814 Wurliizer Drive  
 North Tonawanda, NY 14120  
 Phone: (716) 564-5165  
 Fax: (716) 564-5173

FILE NAME  
 AST\_OST-120  
 GEN ARR.

PLOT SCALE  
 1 TO 1  
 ENGINEER  
 J. M. McMAHON

EFFECTIVITY OR SERIAL NO.  
 DRAWN BY  
 V.CAULEY  
 DATE  
 08/19/09  
 PAGE  
 1 OF 1

TITLE  
 GENERAL  
 ARRANGEMENT  
 AST\_OST-120