

SPECS: AST-200/OST-200

CAPACITY.....200 GALLONS (27 CU. FT.)

WEIGHT.....525 LBS. (236.25 kg)

CODE.....ASME Sec. VIII Div 1

DIMENSIONS:

Diameter.....30" (76.2 cm)

Height (w/base).....Approx. 80"(203.2 cm)

PRESSURE RATING.....200 PSI (TESTED AT 260 PSI)

FITTING SIZES.....F1=2" NPT

F2=1" NPT

F3=1/2" NPT

F4=1/4" NPT

F5=1-1/2" NPT

F6=3" NPT

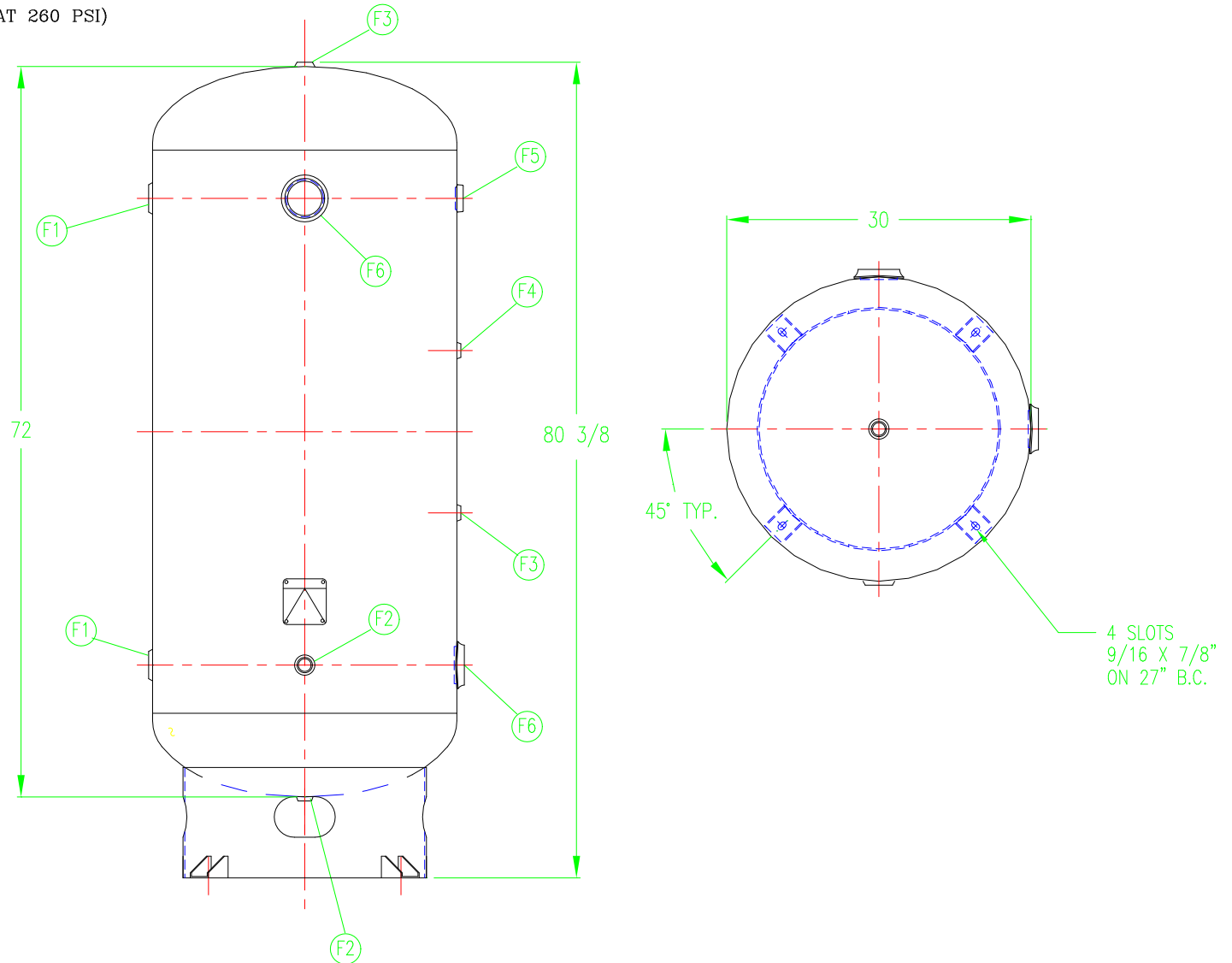

REVISIONS

REV	DESCRIPTION	DATE	CHK	ECN #

OGSI
 814 Wurliizer Drive
 North Tonawanda, NY 14120
 Phone: (716) 564-5165
 Fax: (716) 564-5173

FILE NAME
 AST_0ST-200
 GEN ARR.

PLOT SCALE
 1 TO 1
 ENGINEER
 J. M. McMAHON

EFFECTIVITY OR SERIAL NO.
 DRAWN BY
 V.CAULEY
 DATE
 08/19/09
 PAGE
 1 OF 1

TITLE
 GENERAL
 ARRANGEMENT
 AST_0ST-200