

**SPECS: AST-400/OST-400**

**CAPACITY**.....400 GALLONS (50.33 CU. FT.)

**WEIGHT**.....935 LBS. (420.75 kg)

**CODE**.....ASME Sec. VIII Div 1

**DIMENSIONS:**

Diameter.....36" (91.44 cm)

Height (w/base).....Approx. 102"(259.08 cm)

**PRESSURE RATING**.....200 PSI (TESTED AT 260 PSI)

**FITTING SIZES**.....F1=2" NPT

F2=1" NPT RADIAL FLANGE

F3=1" NPT FLAT FLANGE

F4=3" NPT

F5=1-1/2" NPT

F6=1/4" NPT

F7=1-1/2" NPT

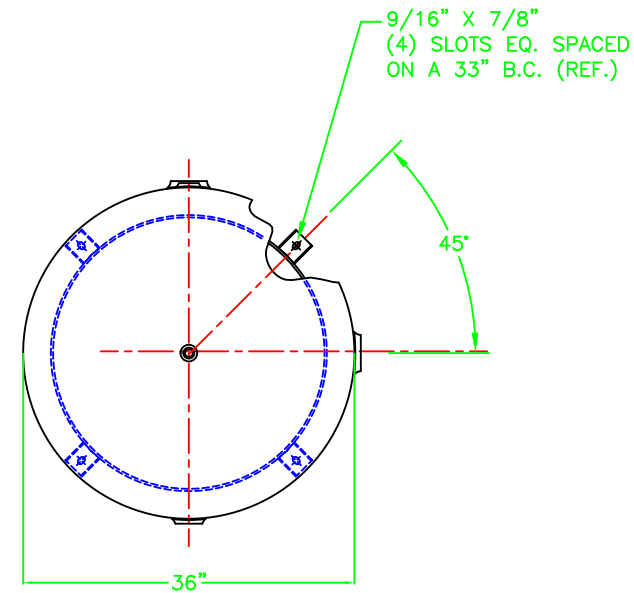
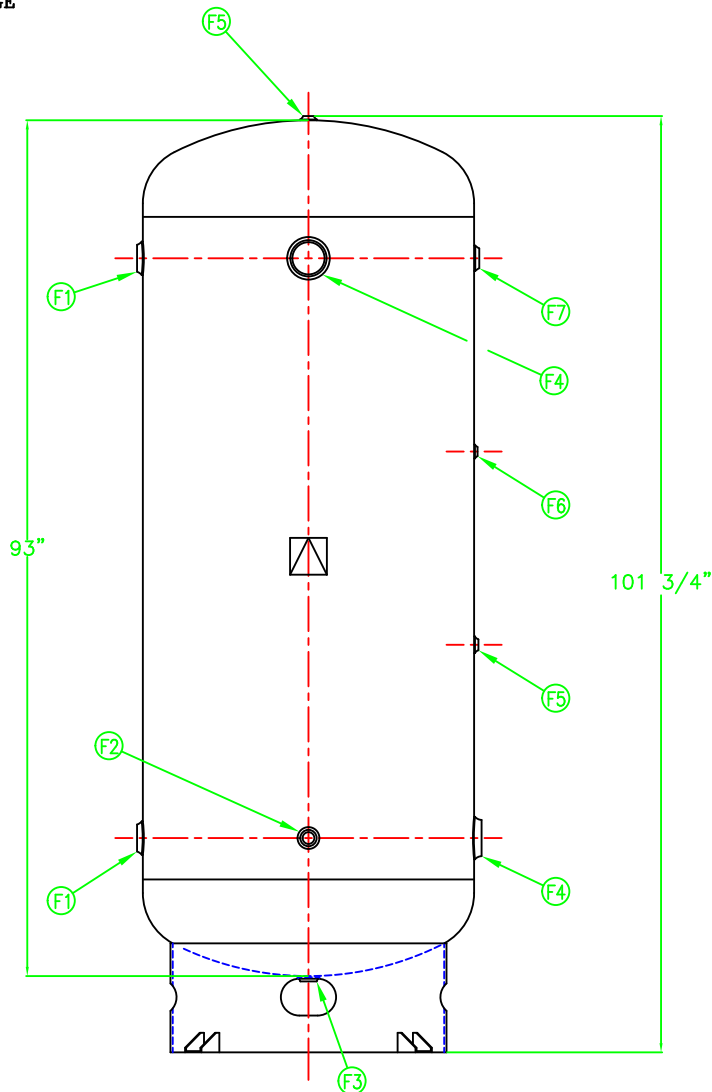

**REVISIONS**

REV	DESCRIPTION	DATE	CHK	ECN #

**OGSI**  
 814 Wurlitzer Drive  
 North Tonawanda, NY 14120  
 Phone: (716) 564-5165  
 Fax: (716) 564-5173

FILE NAME  
 AST\_OST-400  
 GEN ARR.

PLOT SCALE  
 1 TO 1  
 ENGINEER  
 J. M. McMAHON

EFFECTIVITY OR SERIAL NO.  
 DATE  
 08/19/09

DRAWN BY  
 V.CAULEY  
 PAGE  
 1 OF 1

TITLE  
 GENERAL  
 ARRANGEMENT  
 AST\_OST-400