

SPECS: AST-60/OST-60

CAPACITY.....60 GALLONS (8 CU. FT.)

WEIGHT.....159 LBS. (71.55 kg)

CODE.....ASME Sec. VIII Div 1

DIMENSIONS:

Diameter.....20" (50.8 cm)

Height (w/base).....Approx. 51"(130 cm)

PRESSURE RATING.....200 PSI (TESTED AT 260 PSI)

FITTING SIZES.....F1=1/2" NPT

F2=2" NPT

F3=3/4" NPT

F4=1/4" NPT

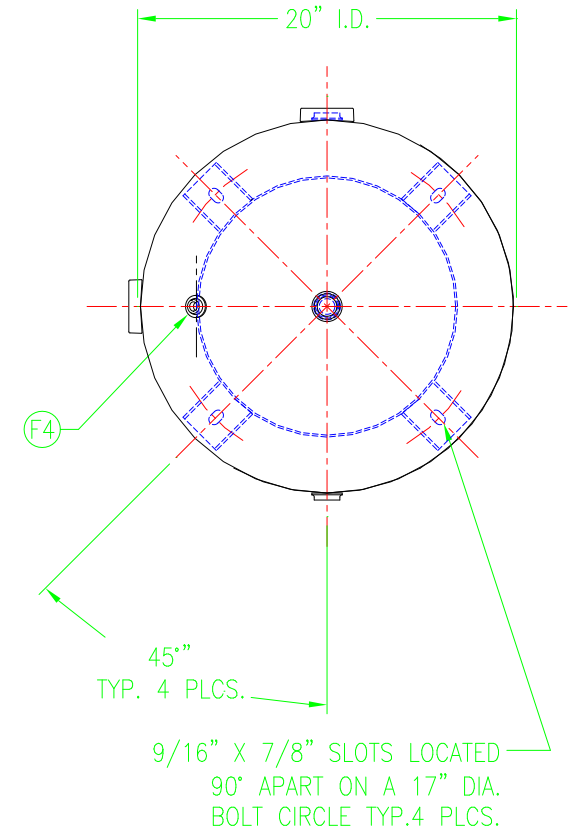
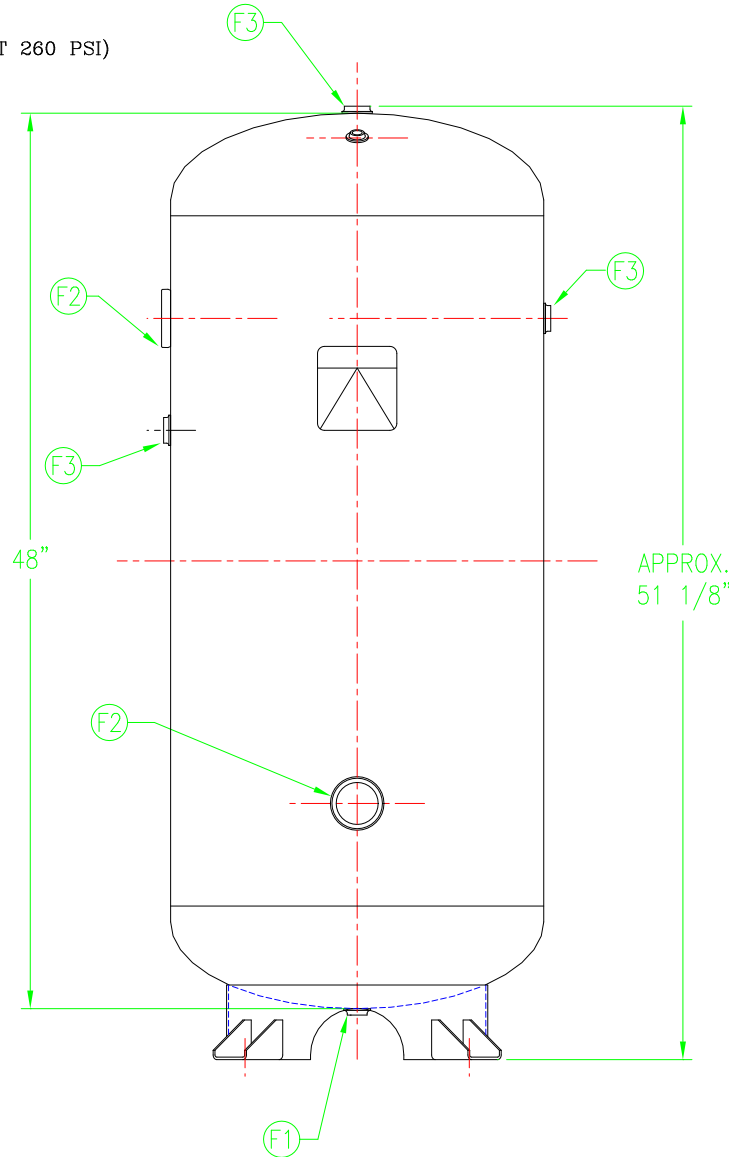

REVISIONS

REV	DESCRIPTION	DATE	CHK	ECN #

OGSI
 814 Wurliizer Drive
 North Tonawanda, NY 14120
 Phone: (716) 564-5165
 Fax: (716) 564-5173

FILE NAME
 AST_0ST-60
 GEN ARR.

PLOT SCALE
 1 TO 1

ENGINEER
 J. M. McMAHON

EFFECTIVITY OR SERIAL NO.

DATE
 08/19/09

DRAWN BY
 V.CAULEY

PAGE
 1 OF 1

TITLE
 GENERAL
 ARRANGEMENT

AST_0ST-60