

Touch Screen Guide

OG-375 through OG-1250

Part # 900000.T08

External View
OG-375 through OG-650

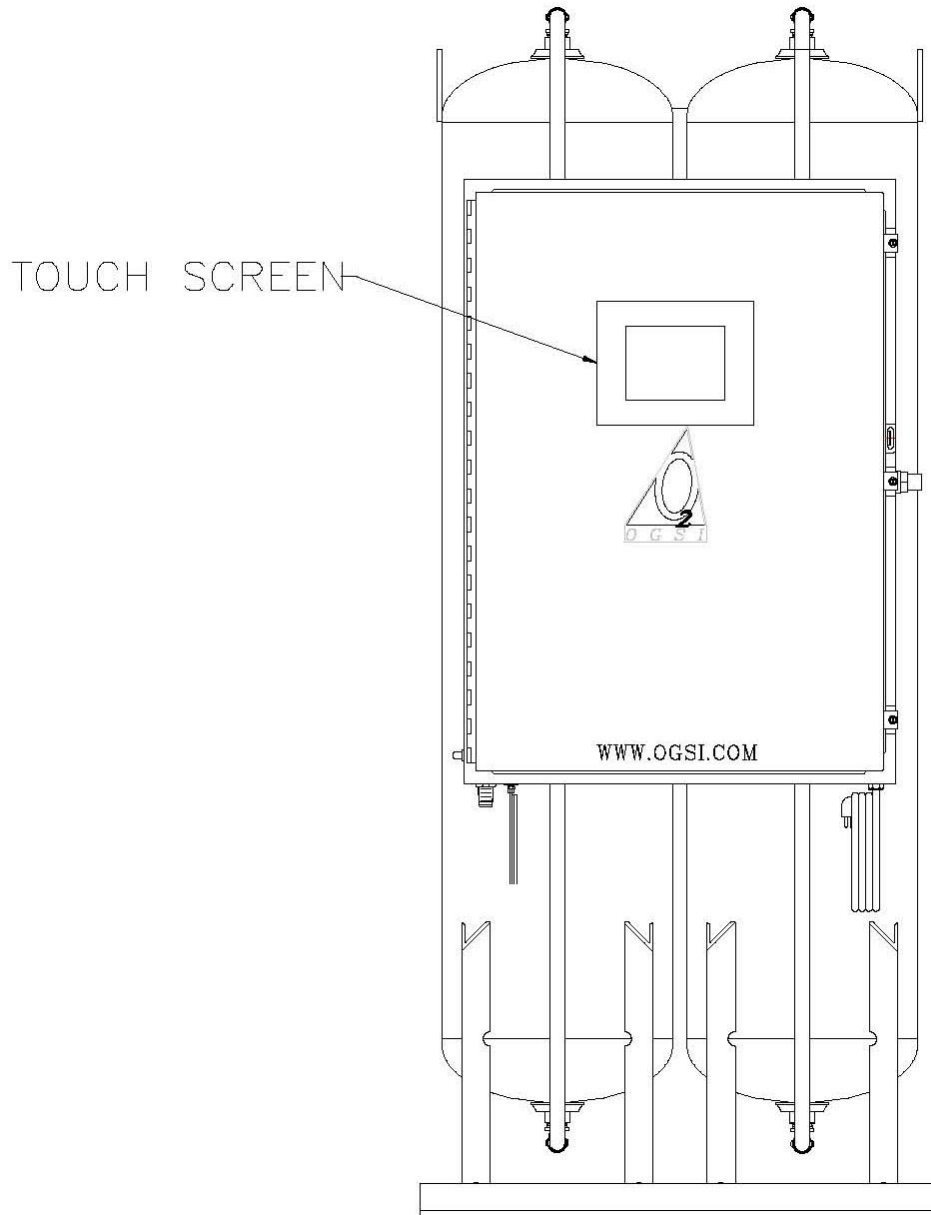

External View
OG-750 and OG-1000

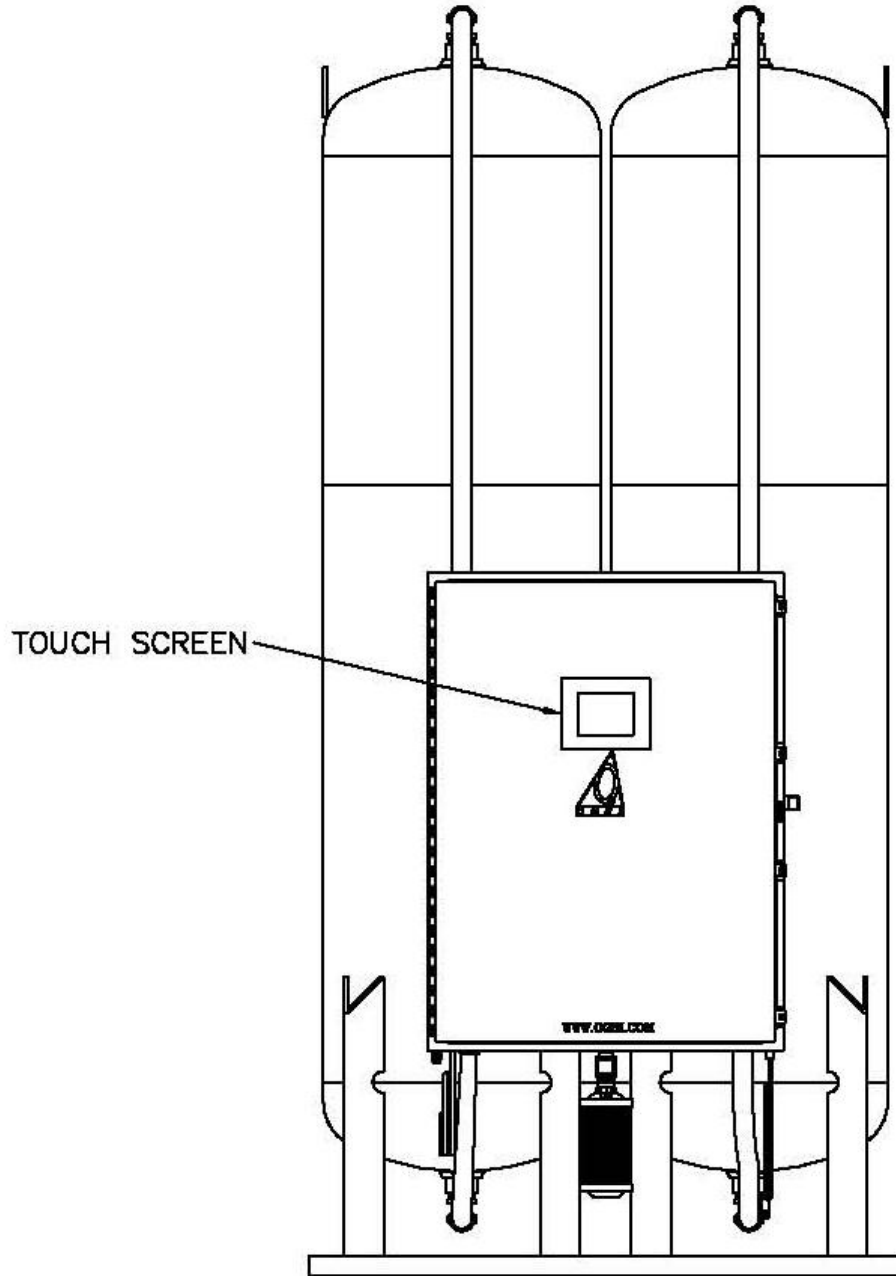

Internal View

OG-375 through OG-650

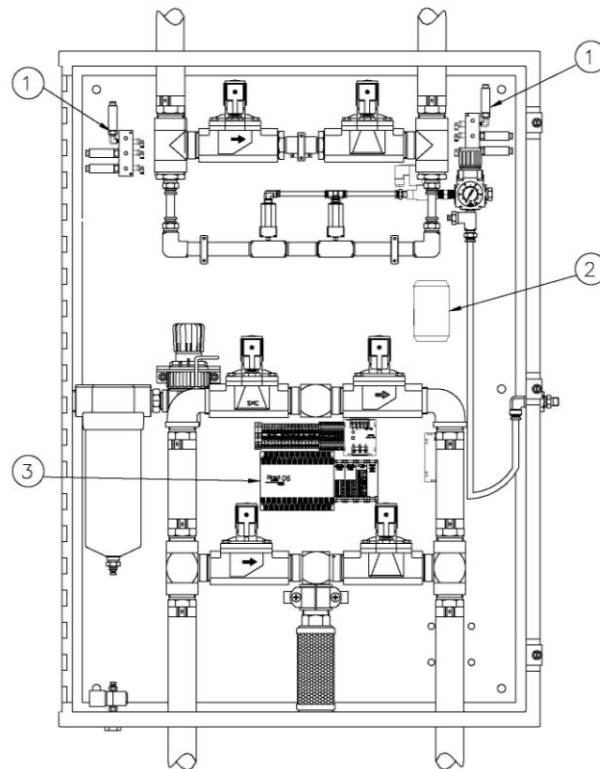

<p>1. Transducer Banks</p>	<p>These are the two manifolds with three (3) transducers in each manifold. The transducers relay the pressure reading from the gas, through the PLC, to the touchscreen for user reference. The transducers read the following pressures:</p> <ul style="list-style-type: none"> • Feed Air Pressure • Oxygen Pressure • The pressure of the gas at the top of Bed A • The pressure of the gas at the bottom of Bed A • The pressure of the gas at the top of Bed B • The pressure of the gas at the bottom of Bed B
<p>2. Oxygen Sensor</p>	<p>This component measures the purity of the oxygen being delivered from the oxygen generator. This reading is sent to touchscreen and is recorded in terms of percentage.</p>
<p>3. PLC</p>	<p>The PLC (Programmable Logic Controller) Model DL06 processes inputs and outputs to and from system components, and communicates with the touch screen. This is the brain of the machine.</p>

Internal View
OG-750 and OG-1000

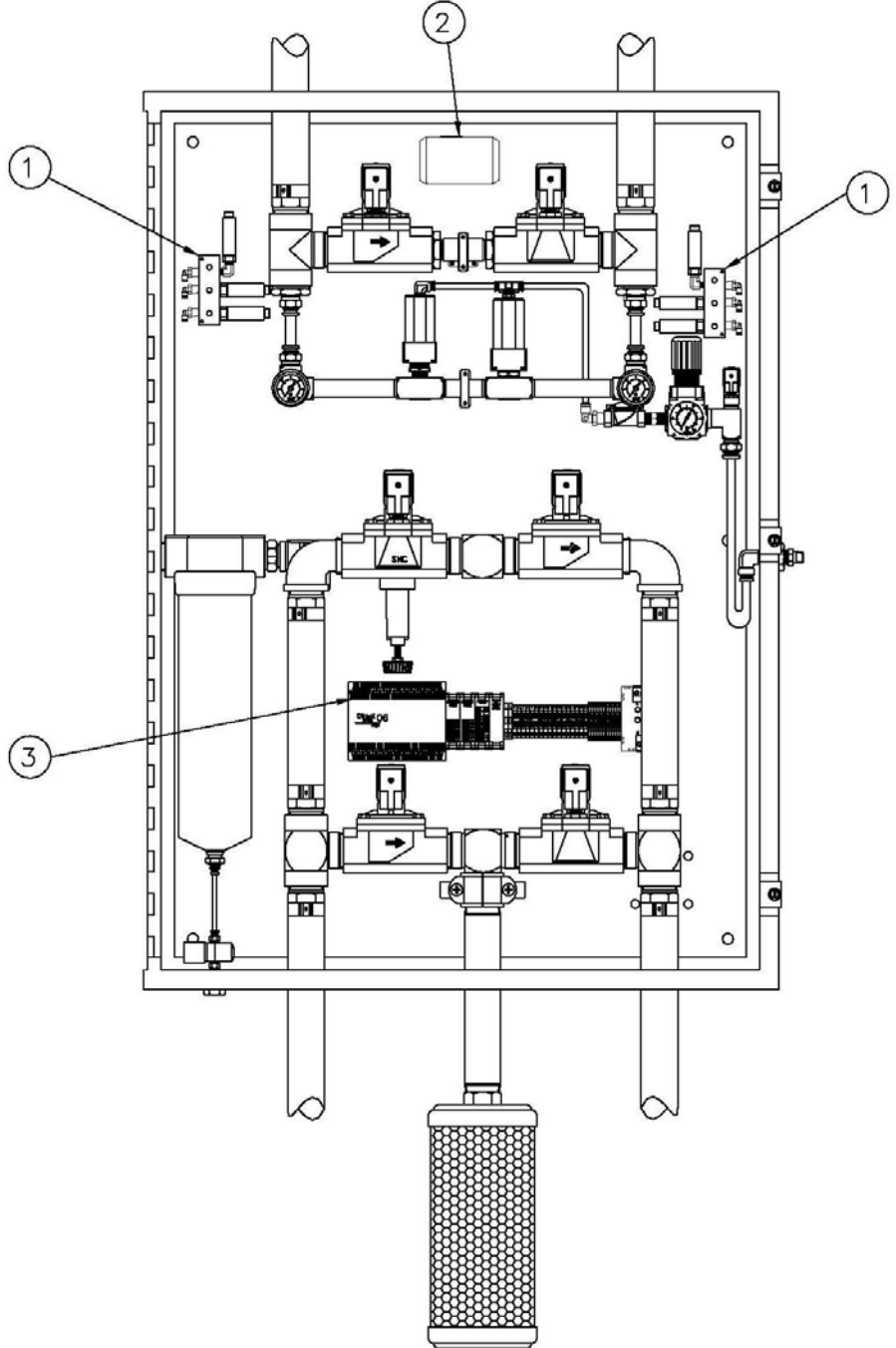

Description – Same as OG-375 through OG-650

Password to Access Touch Screen

647401

Please take appropriate measures to keep this password secure and to prevent unauthorized access.

Touch Screen Overview

The touch screen is the main interface between the operator and machine, and incorporates all controlling mechanisms within its display.

Listed below are the Main Operator Features incorporated within the touch screen:

- Language selection
- Password protection
- Energize/de-energize the machine
- Monitor the condition of valves and compressors
- Monitor all pressures and oxygen concentration/purity
- Set the pressure for cylinder filling at **ON/OFF** set points
- Hours meter and real time clock
- Line graph of time elapsed gauge readings
- Self-diagnostic alarm panel

The following pages give a detailed description of the 8 individual screens.

Language Screen



The language screen enables the user to choose the language – English, French or Spanish. After choosing a language, select **NEXT SCREEN**.

Password Screen

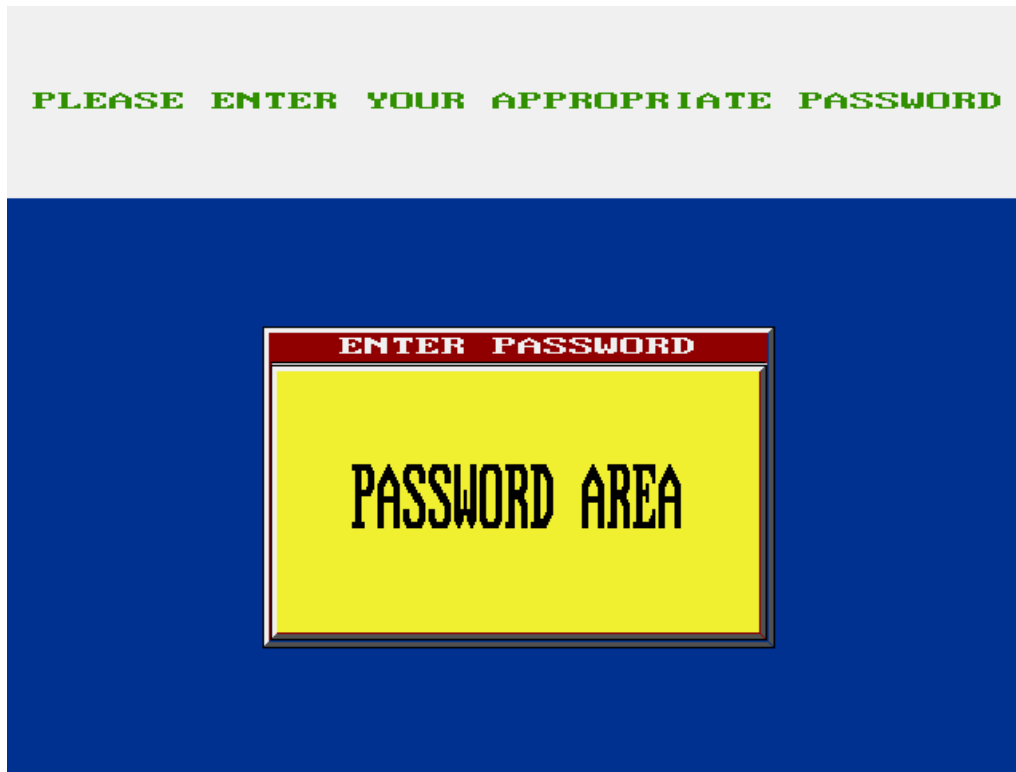

This screen prompts the user to enter the password supplied by the manufacturer.

- Select **PASSWORD AREA**
- Enter the password using the numeric keypad displayed on the screen.
- Select **ENTER**

The password will be verified and the screen will change to the **MAIN MENU** screen when the password is accepted.

Note: The user will not be allowed to change their default password so please keep it secure.

Main Menu Screen



This screen allows the user to navigate through the program from screen to screen and it will get you where you need to go inside the program.

(**Note:** A notification will appear at the top of the screen only if the machine has the timer set and is turned **ON**.)

Control Screen

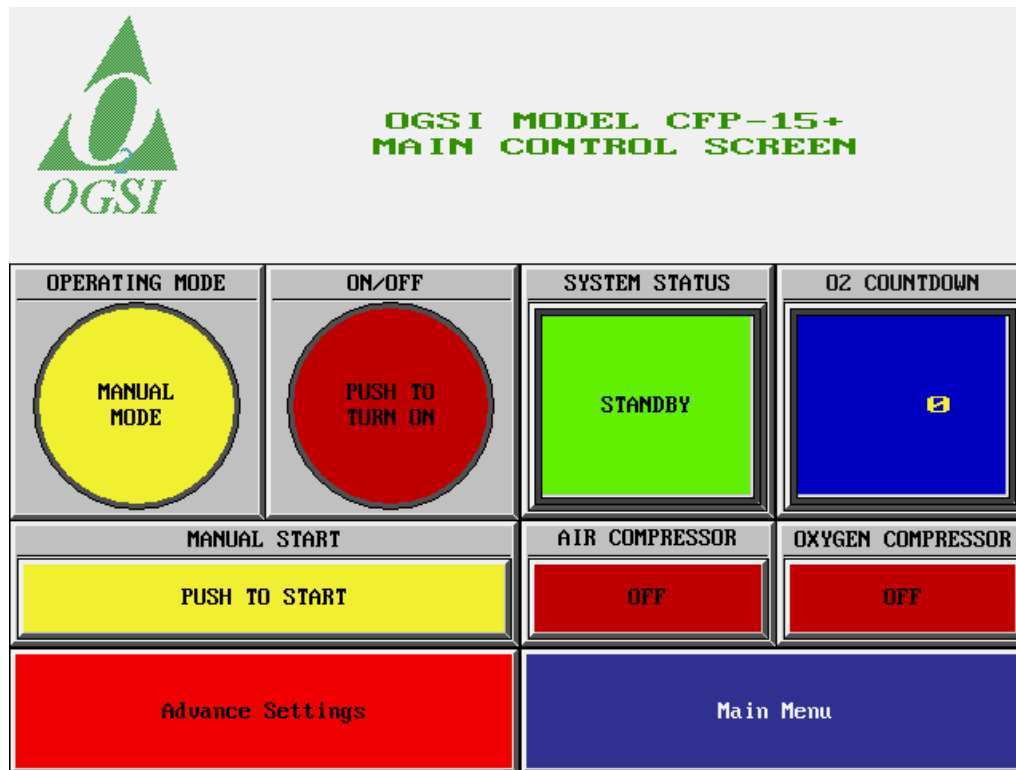

➤ Operating Mode

This feature allows the selection of either **MANUAL** or **AUTOMATIC** modes. The **AUTOMATIC** mode will initiate machine operation when the **ON/OFF** button is in the **ON** position and all other conditions are satisfied. To use the **MANUAL** mode, the user needs to press an additional **START** button. **MANUAL** mode can be used to prevent inadvertent machine operation.

➤ Power

In **AUTOMATIC** mode, the machine will start operating when the button is in the **ON** position. In **MANUAL** mode, the machine will start only when this button is in the **ON** position and the additional **START** button is pressed. The button will stop the machine in either mode of operation when it is in the **OFF** position.

➤ System Status

This feature monitors the current status of the system. It will display **STANDBY** when the system is deactivated and **CYCLING** when the system is activated.

➤ **Manual Start**

This button is used in conjunction with the **MANUAL** mode of operation, and must be pressed each time the system is restarted.

➤ **Air Compressor**

This feature monitors the operational condition of the air compressors. When the air compressors are de-energized, it will display **STANDBY** and will toggle to **RUNNING** when they are energized.

➤ **Oxygen Compressor**

This feature monitors the operational condition of the oxygen compressor. When the oxygen compressor is de-energized, the feature will display **STANDBY**. When the oxygen compressor is energized, it displays **RUNNING**.

➤ **Oxygen Countdown**

This indicator monitors and lets the user know when the oxygen compressor will be turning **ON/OFF**. This indicator resets frequently due to the duty cycle of the oxygen compressor.

➤ **Advance Settings**

This button allows the user to move the timer screen which lets the user set the machine to turn **ON/OFF** at specific times.

Advanced Settings

OGSI

Timer Setup

Starting Hour: 0 Ending Hour: 0

Starting Minute: 0 Ending Minute: 0

Timer
On
Off

Important!!! Make sure to use military time when setting the timer. Use the Realtime clock in the touchscreen.

Back to Controls

This feature allows the user to modify timer settings. If there are particular hours of the day you want the machine to run, you can enter the hour and minutes (military time) you want into the starting and ending time inputs.

Settings Screen

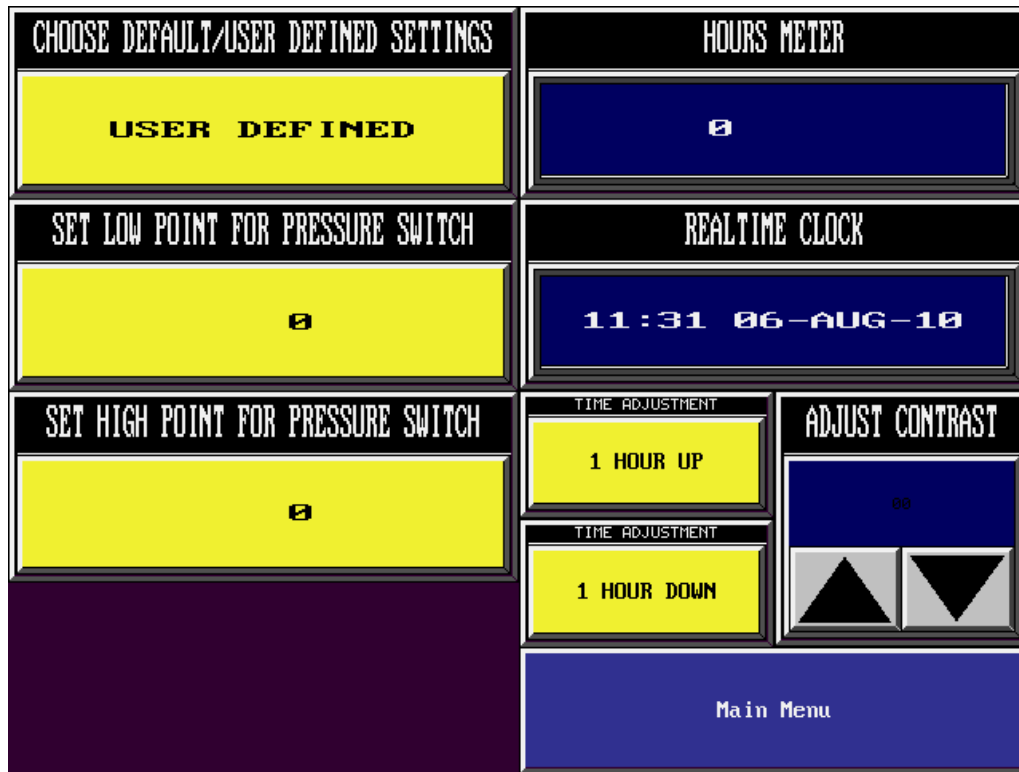

➤ Choose Default/User-defined Settings

This password protected feature allows the user to operate the machine using either the manufacturer's settings or customized settings. The manufacturer's settings are set at **1950 psi (135 bar)** and **2200 psi (152 bar)**. When the high point of this setting is reached, the machine will de-energize and the cylinder filling will cease.

To customize the settings, enter the low and high pressures using the displayed numeric keypads. When the cylinder pressure drops to the low point, the machine re-energizes and cylinders can be filled once again to the high point.

➤ Set Low Point for Pressure Switch

This is a password protected feature that allows the user to customize the low-pressure setting. Valid entries are between **0-2050 psi (0-141 bar)**. A warning will be displayed if the low-pressure entry is higher than the high-pressure entry and the system will not operate.

➤ **Set High Point for Pressure Switch**

This is a password protected feature that allows the user to customize the high-pressure setting. Valid entries are between **0-2200 psi (0-152 bar)**. A warning will be displayed if the high-pressure entry is lower than the low-pressure entry and the system will not operate.

➤ **Hours Meter**

This meter displays the accumulated operating time of the system. This meter will increment only while the system status is **CYCLING** and will reset to zero after 10,000 hours. Most maintenance will be related to the number of hours the machine has been operating.

➤ **Real-time Clock**

This is a password-protected feature that allows the user to synchronize the system's clock according to the current time-zone.

➤ **Adjust Contrast**

This button allows the user to adjust the screen brightness according to his/her eyes' sensitivity.

Gauge Screen

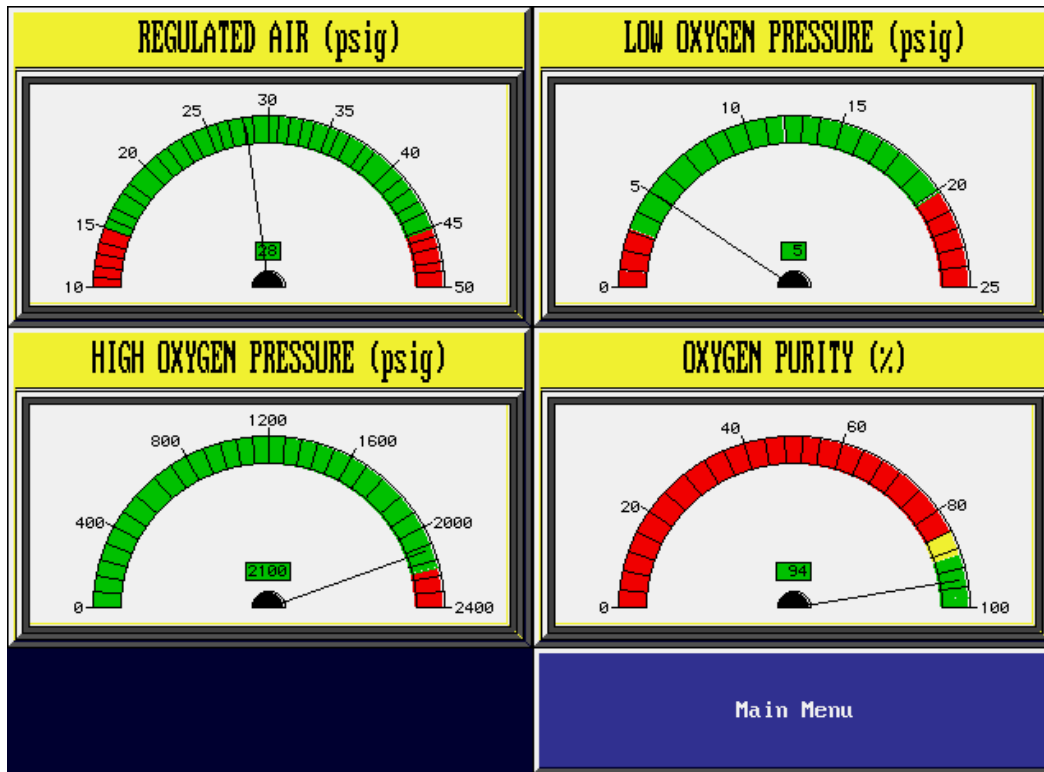

➤ **Regulated Air**

This feature displays the pressure associated with the air compressor. This pressure is typically between **15 psi (1 bar)** and **35 psi (2.4 bar)**.

➤ **Low Oxygen Pressure**

This feature displays the oxygen pressure prior to entering the high-pressure oxygen compressor. This pressure is typically around **5 psi (0.3 bar)**.

➤ **High Oxygen Pressure**

This feature displays the oxygen pressure exiting the high-pressure oxygen compressor (entering the cylinders). This pressure is typically between **0 psi** and **2200 psi (152 bar)**.

➤ **Oxygen Purity**

This feature displays the percentage of oxygen present which is typically **93% (±3%)**.

Pressure-Line Graph Screen

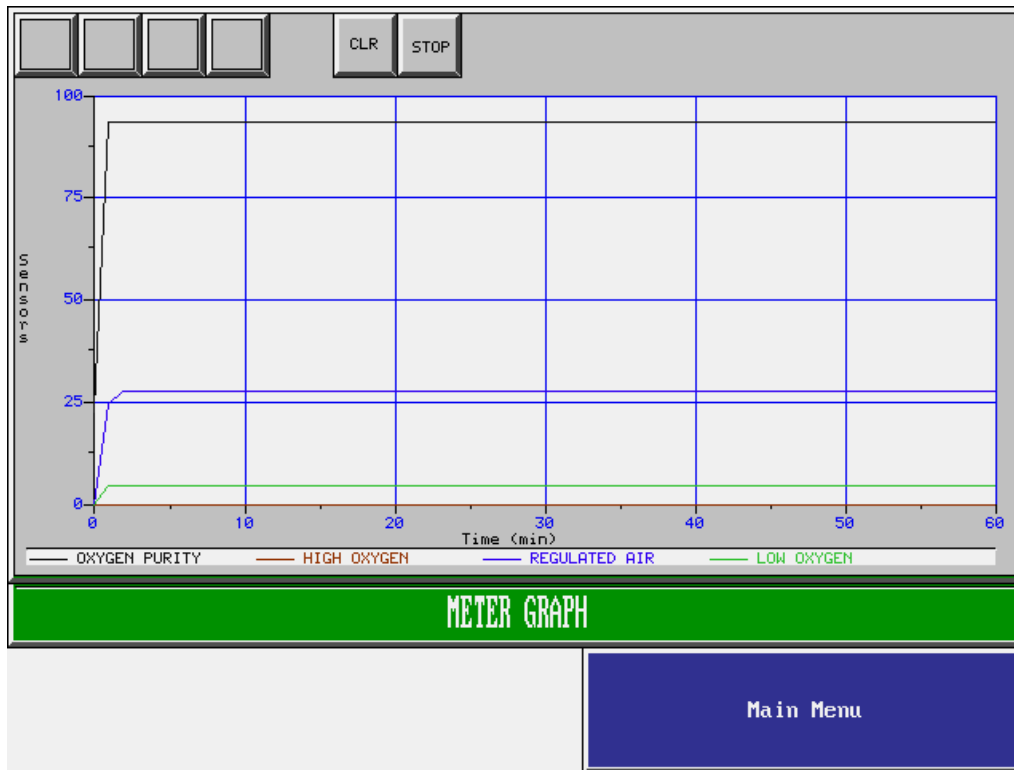

This screen shows the graph based on the readings on the **GAUGE** screen. Note that the high-pressure oxygen display has been scaled down by a factor of 100. **60** minutes are displayed at a time and 24 hours of chart readings are stored in memory. If power to the machine is lost (**Emergency-Stop** button is pushed in, machine is unplugged, etc.), the chart memory will be lost.

Alarm Screen

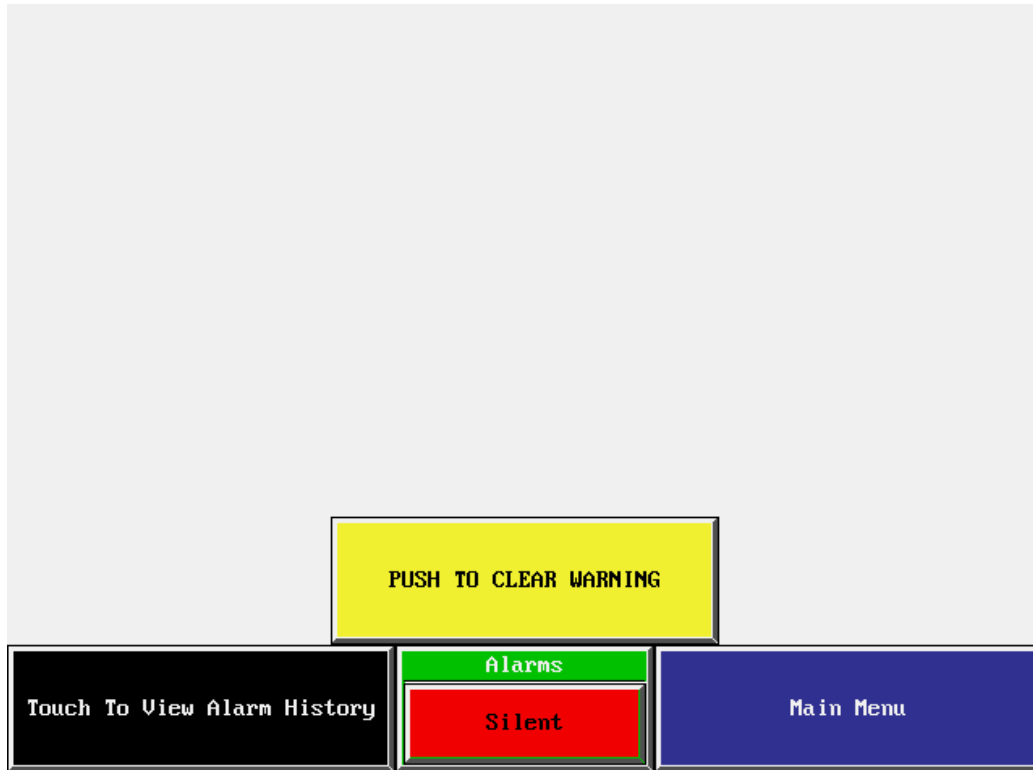

This feature displays warnings when any of the following faults occur:

- Oxygen pressure has fallen below acceptable limits. (This fault does not de-energize the machine.)
- Oxygen purity has fallen below acceptable limits.
- Oxygen compressor pressure switch has tripped.
- Air compressor thermal switch has tripped.
- Oxygen compressor thermal switch has tripped.
- Air compressor has been running one hour, and the purity has not yet reached an acceptable level.

Instructions will be displayed on the screen to clear any warnings. For certain alarms, the machine will not operate until the '**CLEAR WARNING**' button has been pressed.

Final Screen

For any problems with this system contact
OGSI at
(800) 414-6474 or Fax (716) 564-5173 or
Tel. (716) 564-5165
or Visit our site web a www.ogsi.com
email ogsimail@ogsi.com

Model Number CFP-15M

Serial Number - 08BCFP15M03

Oxygen Purity - 93%

DATE OF COMPLETION 01/09/08

Software Versions:
CFP15MV4.prj
CFP15MV4.ezt

Main Menu

This screen displays information pertinent to the system, and manufacturer contact information. The Model Number of the Machine and its Serial Number are displayed along with the Date of Completion. The software versions for both the Programmable Controller and Touch Screen are also shown. During the course of normal maintenance, the company may offer to upgrade the software packages on the machine as improvements and modifications to it become available.

Correcting Missing or Irregular Touch Screen Color Scheme

- Ensure that the machine is not in cycling mode and leave the power button in the **ON** position.
- Touch both the top left corner and the bottom left corner of the touch screen at the same time.

**Press both
corners at the
same time**

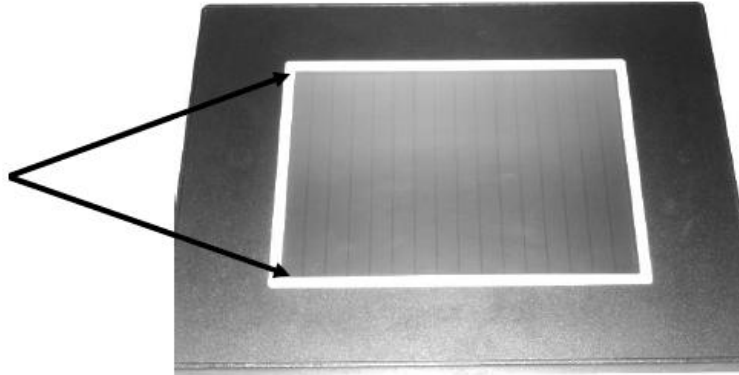

- Select the appropriate language – English or Spanish.
- Select **CONTRAST** and use the up and down arrows to change the contrast settings to get the clearest picture. Select **EXIT** when done to return to the main menu.
- Select **DISPLAY TEST**. The screen will display all the colors continuously, allowing the user to see if a color is not displayed correctly. Select **EXIT** at any time to go back to the previous screen.
- Select **TOUCHPAD TEST**. The screen will display a grid. The user can select each square in the grid to ensure that all sections of the screen are responding. Select **EXIT** to return to the main menu.
- Select **EXIT** when done to return to the screen displayed before the two corners were pressed.