



OG-15 • MID-SIZE GENERATORS •
 TONNAGE PLANTS • CYLINDER FILLING PLANTS

HOSPITAL SYSTEMS

Durability By Design

...an 80% reduction in cost...



Lower Your Facility's Operating Costs - take oxygen directly from the air.

Eliminate the expense of purchasing, receiving, and monitoring your hospital's oxygen supply. Oxygen Generating Systems, Inc. designs, builds and installs turn-key medical PSA oxygen systems worldwide. Our equipment is fully automatic, easy to maintain, and produces a continuous flow of medical grade oxygen. Join the growing number of hospitals that have ended their expensive reliance on liquid and compressed oxygen.

Economical

A modest capital investment in an OGSi system can result in up to an **80% reduction** in your facility's cost of oxygen. Our systems average only 3 kilowatts of electricity per 100 cubic feet of oxygen produced. Most OGSi systems pay for themselves within months.

OGSi Equipment Operating in Over 40 Countries

With our worldwide base of installed equipment, OGSi has the engineering and manufacturing experience to meet your facility's needs. Our sales and service network is dedicated to keeping your oxygen generator system in top condition.



Medical Oxygen Generator Skid

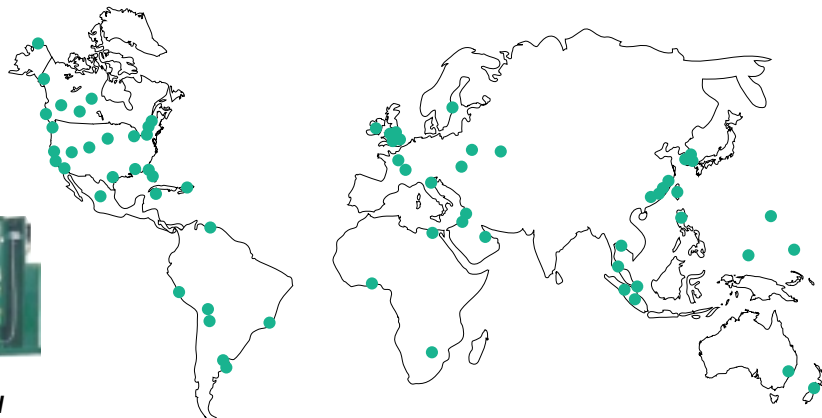

APPLICATION NOTE
 Oxygen Generating Systems Inc.

1-800-414-OGSI • 716-731-1455
6474

www.ogsi.com

93% Oxygen Safe for Medical Use

OGSI equipment is fabricated in accordance with all relevant codes (ASME, ANSI, NEMA, CE), and can be configured to meet CRN and CSA standards. Oxygen produced meets the United States Pharmacopeia (USP) XXII Oxygen 93% Monograph.



OXYGEN 93 PERCENT

USP requirements: Oxygen 93 Percent USP—Preserve in cylinders or in a low pressure collecting tank. Containers used for Oxygen 93 Percent must not be treated with any toxic, sleep-inducing, or narcosis-producing compounds, and must not be treated with any compound that will be irritating to the respiratory tract when the Oxygen 93 Percent is used. It is Oxygen produced from air by the molecular sieve process. Where it is piped directly from the collecting tank to the point of use, label each outlet "Oxygen 93 Percent." Contains not less than 90.0% and not more than 96.0%, by volume, of oxygen, the remainder consisting mostly of argon and nitrogen. Meets the requirements for Identification, Odor, Carbon dioxide (not more than 0.03%), and Carbon monoxide (not more than 0.001%).

Fully Automatic

OGSI can design and install a medical oxygen system with the proper reserve capabilities, monitoring and alarm systems to meet local safety requirements. In the unlikely event the system deviates from its pre-set limits, it automatically switches to the secondary oxygen supply. The system's alarm calls attention to the problem so that corrective service can be performed. An optional telemetry package allows OGSI's factory engineers to remotely monitor the system.

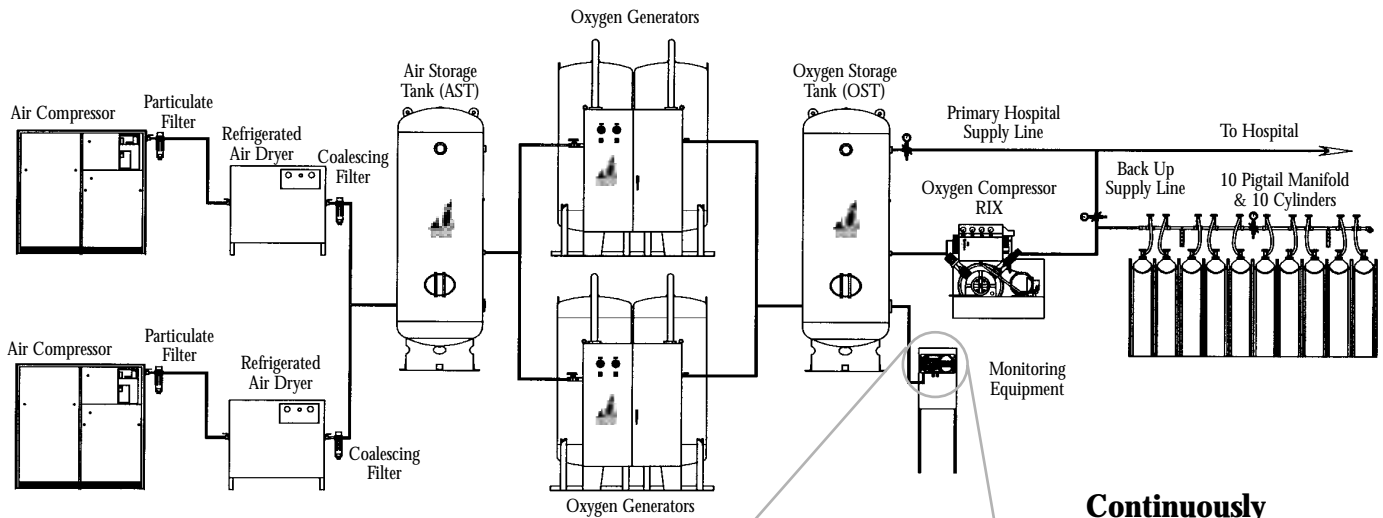

Easy to Maintain

Each system can be operated without extensive technical knowledge or training. Easy to follow manuals, videos and on-site training will teach your staff how to properly calibrate and maintain the system. Routine maintenance is limited to normal air compressor upkeep and periodic replacement of oxygen generator filter elements.

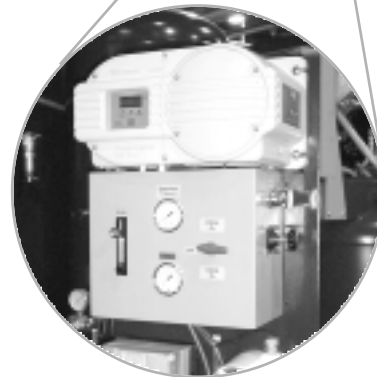

Continuously Monitored Purity and Flow

All medical systems come equipped with a continuous monitoring station. This device ensures that the medical oxygen's purity and concentration of CO and CO₂ gas remain within acceptable limits.

