



OG-375 through OG-1250 Oxygen Generators

Installation, Operation and Maintenance Manual



Oxygen Generating Systems Intl. (OGSI)

Division of Audubon Machinery Corporation

814 Wurlitzer Drive, North Tonawanda, New York 14120 USA

Tel: (716) 564-5165 **Toll Free:** (800) 414-6474 **Fax:** (716) 564-5173

E-mail: ogsimail@ogsi.com

Website: www.ogsi.com

Part # 9000000.008

US \$25.00

Table of Contents

Topic	Page Number
Using this Manual	1
Initial Inspection	2
Warranty Information and Liabilities	3
Safety Guidelines	5-6
➤ Handling	5
➤ Operating	6
Product Information	7-26
➤ Features and Applications	7
➤ PSA Technology	9
➤ Components	10
➤ Process Flow Description	23
➤ Set-up and Connection Diagrams	24
➤ Specifications	26
Safety Precautions	29
Pre-Installation	30
Required Operating Conditions	31
Sieve Repacking Instructions	33
Set-up and Installation	35
Operating Instructions	37
Troubleshooting Guide	39
Preventive Maintenance	40
Technical Service Assistance	42
Appendix	I-VIII
➤ Spare Parts List	I
➤ Oxygen Cleaning Procedure	IV
➤ Air Changes by Room Size	VI
➤ Units of Measurement	VII
➤ Maintenance Log	VIII

©2010, *OGSI*. All rights reserved. *OGSI* is a registered trademark.
This publication may not be reproduced in part or whole without written permission of *OGSI*.

Using the Manual

This manual is intended as a guide for operators of **OGSI** Oxygen Generators and Oxygen Generating Systems. It includes information on our warranty policy, features, functions, applications, proper set-up and installation, operation and maintenance of our products.

The following symbols are used throughout the manual:



Information
(Do not use product before reading the manual)

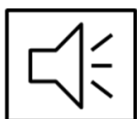

Sound



No Smoking



No Open Flames



Flow Meter



No Oil



Electrical Hazard



Fire Hazard



Warning



Power ON/OFF



Timer



Not Connected to Outlet



Initial Inspection

The crate should be opened and inspected immediately upon delivery. Unpack the unit at once and perform a visual inspection to determine if it is dented, bent or scratched. Also check to make sure the power cord is attached and that the control panel has not been damaged in any way during shipment.

If for any reason the unit should need to be returned in the future, the original crate is the best way to ship it back to the manufacturer. Claims of damage due to freight handling can only be filed by you, the consignee, as **OGSI** shipping terms are Free On Board (FOB), North Tonawanda, NY USA. This means that once the equipment leaves our dock you are the owner of it. **OGSI** has no legal claim to make against any shipping company for damage.

At **OGSI**, we are committed to using shipping companies with good reputations for taking care in the handling of freight and providing service in the event of damage.

Warranty

Oxygen Generating Systems Intl., being a division of Audubon Machinery Corporation (hereinafter **OGSI**), provides a warranty on its products (the “Products”) against defects in material and workmanship, under normal use and operation, to the extent set forth in this Warranty.

THIS WARRANTY IS THE SOLE AND EXCLUSIVE WARRANTY OF **OGSI** WITH RESPECT TO THE PRODUCTS AND IS IN LIEU OF ALL OTHER WARRANTIES EXPRESSED OR IMPLIED ALL OF WHICH ARE HEREBY DISCLAIMED TO THE FULLEST EXTENT PERMITTED BY APPLICABLE LAW. WITHOUT LIMITING THE GENERALITY OF THE FOREGOING DISCLAIMER AND EXCEPT AS OTHERWISE SET FORTH IN THIS WARRANTY, **OGSI** DISCLAIMS ALL WARRANTIES OF MERCHANTABILITY WITH RESPECT TO THE PRODUCTS AND ALL WARRANTIES OF FITNESS FOR A PARTICULAR PURPOSE. THE WARRANTY OF **OGSI** AS SET FORTH HEREIN IS FOR THE BENEFIT OF THE ORIGINAL USER OF THE PRODUCTS AND IS NOT TRANSFERABLE WITHOUT THE PRIOR EXPRESS WRITTEN CONSENT OF **OGSI**.

The **OGSI** Warranty provides the following:

- 1) **OGSI** shall repair or replace the Products free of charge to the original user where defects in the material and/or workmanship are evident at the time of delivery. Such replacement of the Products does not include damages incurred in shipping the Products. If shipping damage is evident, the original user should contact the shipper immediately. **OGSI** will pay for shipping the Products to the original user as well as returning damaged/defective Products to **OGSI**. Once the Products are repaired, **OGSI** will ship the Products back to the original user and cover all costs incurred in shipping.
- 2) **OGSI** shall repair or replace the Products (excluding filter elements and sieve material) free of charge to the original user where defects in material and/or workmanship become evident between the time of delivery to the original user and one (1) year from the date of delivery to the original user. **OGSI** will pay for shipping the Products to the original user as well as returning damaged/defective Products to **OGSI**. Once the Products are repaired, **OGSI** will ship the Products back to the original user and cover all costs incurred in shipping. In no event shall **OGSI** have any responsibility or liability for the cost of labor for the removal of component parts or equipment that constitute part of the Products, packaging of the component parts or equipment that constitute part of the Products or the re-installation or replacement of the component parts or equipment that constitute part of the Products.
- 3) The warranty provided by **OGSI** to the original user covers parts and equipment specifically manufactured by **OGSI** and used as components or equipment that constitute part of the Products. The warranty on parts or equipment manufactured by third parties and included as part of the Products (*e.g., air dryers, air compressors, oxygen compressors, instrumentation, etc.*) is limited to the respective original warranties of such third parties.

Note: A *Return Authorization Number* must be obtained from **OGSI** prior to the return shipment of the Product or any component parts or equipment of the Products.

The *Return Authorization Number* must be visibly written on the outside of the package of the returned Products, component parts or equipment as applicable or **OGSI** will not accept the return.

Note: A *Credit Certificate* will be created for all Warranty Exchange transactions. **OGSI** will provide the *Credit Certificate* with an invoice at the time of shipment to the original user. The *Credit Certificate* must be included in the package to **OGSI** with the returned products within 30 days of the date of the invoice. Failure to return Warranty Exchange Products to **OGSI** within 30 days will make the Warranty Exchange process void and payment for Products will be billed and due on receipt.

Note: The warranties of **OGSI** as set forth herein shall also become null, void and not binding on **OGSI** if a defect or malfunction occurs in the Products or any part of the Products as a result of:

- a) A failure to provide the *Required Operating Conditions* for the Products
(See Pages 31-32)
- b) Repair, attempted repair, adjustment or servicing of the Products, or any component parts or equipment that constitutes part of the Products by anyone other than an authorized representative of **OGSI**. The authorized service representative must obtain prior approval from **OGSI**'s Service Manager before performing any warranty work.
- c) External Causes (e.g. flood, hurricane, tornado, fire, any natural disaster, or any event deemed an act of God).

Molecular Sieve Replacement:

The breakdown of the molecular sieve inside the generator (dusting of the sieve) only occurs if excess water/oil is entrained in the feed air stream. Under no circumstances is the molecular sieve covered under any warranty by **OGSI**. If sieve dusting occurs on your machine, check the air compressor, air dryer and filter elements.

Other Matters:

OGSI is not liable for any special, indirect, punitive, economic, incidental or consequential losses or damages including without limitation, loss of use, malfunction of **OGSI** products, replacement oxygen charges, delays or lost savings related to the Products or otherwise even if **OGSI** shall have been advised of the possibility of such potential losses or damages.

Limits of Liability

OGSI Oxygen Generator products shall not be used for breathable or medical oxygen applications, unless they are assembled with the appropriate support equipment, tested, and operated in compliance with either American, Canadian or ISO norms for hospital oxygen systems.

Safety Guidelines



Handling of Compressed Gas Cylinders

Many of the following procedures for the handling, storage, and utilization of compressed gas in cylinders are taken from material furnished by the Compressed Gas Association, which complies with **OSHA** standards.



Always ensure that compressed gas cylinders are securely strapped or chained in place to prevent tipping or falling. Do not store near elevators, stairs, or passageways.



Do not place cylinders in a position where they might become part of an electric circuit. When electric welding is taking place, precautions should be taken to prevent accidental grounding of cylinders, permitting them to be burned by electric welding arc.

If visual inspection indicates obvious damage, the cylinder should be returned to the supplier without any attempt at using the machine.

If cylinder leaks, other than normal venting, and the leak cannot be corrected by tightening a valve gland or packing nut, the valve should be closed and a tag attached stating that the cylinder is not serviceable. Remove the cylinder outdoors to a well-ventilated or open area, notify the supplier, and follow the supplier's instructions for the return of the cylinder.

Keep the cylinder valve closed at all times except when in active use. When removable caps are provided for valve protection, they should not be removed except for active use. Remember to replace removable caps when not in use.

Cylinders should not be dropped or permitted to strike each other or any other surface. Do not drag or slide cylinders; use a suitable hand truck, fork truck, roll platform or similar device, firmly securing the cylinders for transporting.

Do not store oxygen cylinders with flammable gas cylinders. Stored oxygen and fuel gas cylinders should be at least **20 ft** apart; preferably separated by a fire resistant partition.

*For additional information refer to the CGA publications that can be found at <http://www.cganet.com>
See also ISO publication 10083 that can be found online at <http://www.iso.org>*



Operating

OGSI Oxygen Generators are self-contained systems for the production of high concentration oxygen. Although oxygen itself is not combustible, it can be very dangerous. It greatly accelerates the burning of combustible materials.



Precautions should be taken to avoid a fire in the area of the generator.



Smoking should not be permitted in the area where the generator is located.



All oxygen connections and hoses should be kept clean and free of grease, oil and other combustible materials.



Valves controlling oxygen flow should be opened and closed slowly to avoid the possibility of fires or explosions that can result from adiabatic compression.



Do not attempt to modify or enhance the performance of an oxygen generator in any way.

When bleeding a tank or line, stand clear and do not allow oxygen to embed itself within clothing. A spark could ignite the clothing violently.

Product Information



Features and Applications

The **OGSI** models **OG-375** through **OG-1250** extract oxygen from the air using Pressure Swing Adsorption (PSA) technology. It allows users to generate medical-grade oxygen (conforming to United States Pharmacopeia (USP) XXII oxygen 93% Monograph). It concentrates oxygen up to **93% ($\pm 3\%$)** purity.

Features

Dependable

- **OG-375** through **OG-1250** units are built to provide thousands of hours of continuous, reliable service. The Zeolite sieve is factory sealed in solid steel tanks and rarely needs replacement. Routine maintenance is as simple as changing an air filter.

Durable

- **OG-375** through **OG-1250** units have precision-welded tank assemblies (ASME coded) and oxygen-clean brass tubing and valves which allow the units to operate in extreme conditions.

Economical

- Oxygen is free! The **OG-375** through **OG-1250** units eliminate the unnecessary costs involved in transportation, storage and cylinder rental.

Applications

The **OG-375** through **OG-1250** units can be used in various applications. A few examples are given below.

Hydroponics



Furnace Enhancement

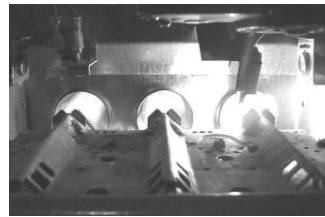

Steel Production



Biotechnology



Welding Shop



Pressure Swing Adsorption (PSA) Technology

An **OGSI** Oxygen Generator is an on-site oxygen generating machine capable of producing oxygen on demand in accordance with your requirements. In effect, it separates the oxygen (21%) from the air it is provided and returns the nitrogen (78%) to the atmosphere through a waste gas muffler. The separation process employs a technology called **Pressure Swing Adsorption (PSA)**. At the heart of this technology is a material called Molecular Sieve (Zeolite). This sieve is an inert, ceramic-like material that is designed to adsorb nitrogen more readily than oxygen. Each of the two beds that make up the generator contains this sieve. The process is described below.

Stage 1

Compressed air is fed into the first molecular sieve bed. Nitrogen is trapped, while oxygen is allowed to flow through.



Stage 2

When the sieve in the first bed becomes full of nitrogen, the airflow is then directed into the second bed.



Stage 3

As the second bed separates the oxygen from the nitrogen, the first bed vents its nitrogen into the atmosphere.



Stage 4

Compressed air is once again fed into the first bed and the process is repeated continuously. A constant flow of oxygen is produced.



This air separation process is reliable and virtually maintenance-free. The molecular sieve will last indefinitely, as long as it does not become contaminated with water or oil vapors. This is why regular filter element replacement is crucial to trouble-free operation. The filter elements are inexpensive and require semi-annual maintenance.

External Components

OG-375/OG-500/OG-650

Front View

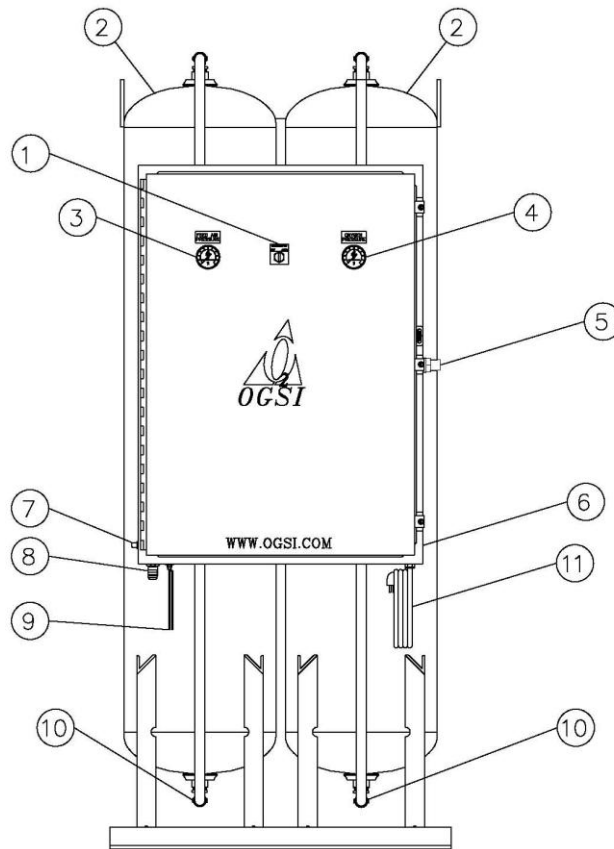

1. OFF/CONTINUOUS/AUTO Selector Switch

2. Sieve Beds

3. Feed Air Pressure Gauge

4. Oxygen Pressure Gauge

5. Oxygen Outlet

6. Hours Meter

7. Manual Filter Drain Button

8. Feed Air Inlet

9. Filter Drain

10. Safety Relief Valve

11. Power Cord

OG-750/OG-1000/OG-1250

Front View

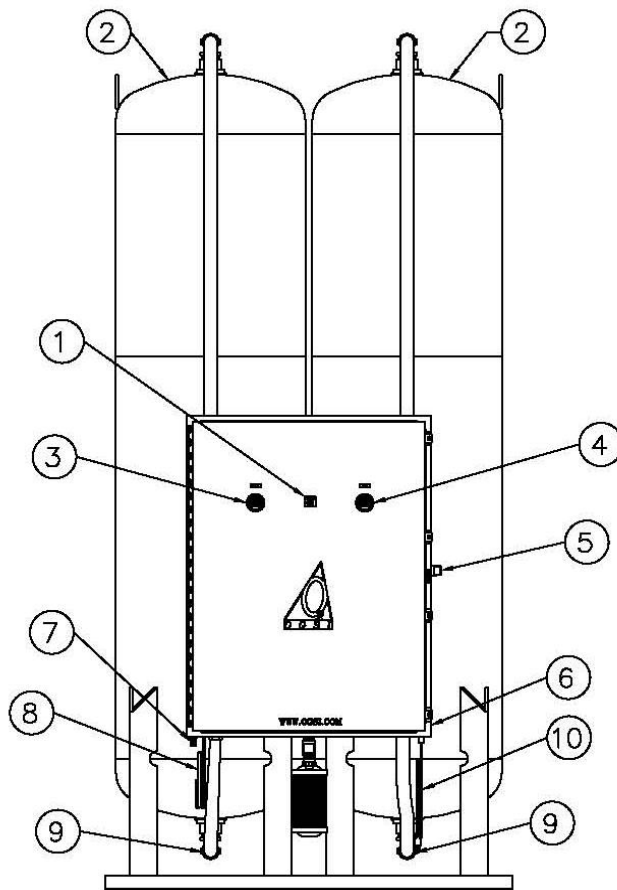

- | | |
|---|-------------------------------|
| 1. OFF/CONTINUOUS/AUTO Selector Switch | 7. Feed Air Inlet |
| 2. Sieve Beds | 8. Filter Drain |
| 3. Feed Air Pressure Gauge | 9. Safety Relief Valve |
| 4. Oxygen Pressure Gauge | 10. Power Cord |
| 5. Oxygen Outlet | |
| 6. Hours Meter | |

Side View

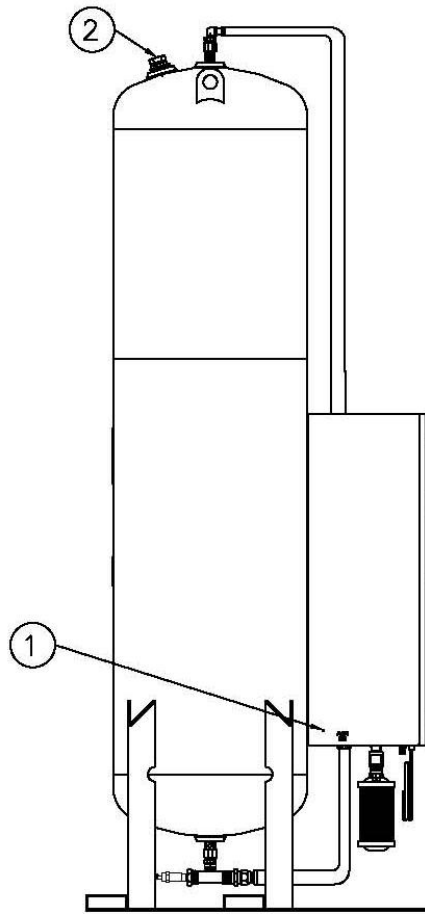

- 1. Manual Filter Drain Button**
- 2. Sight Glass Port**

Oxygen Storage Tank

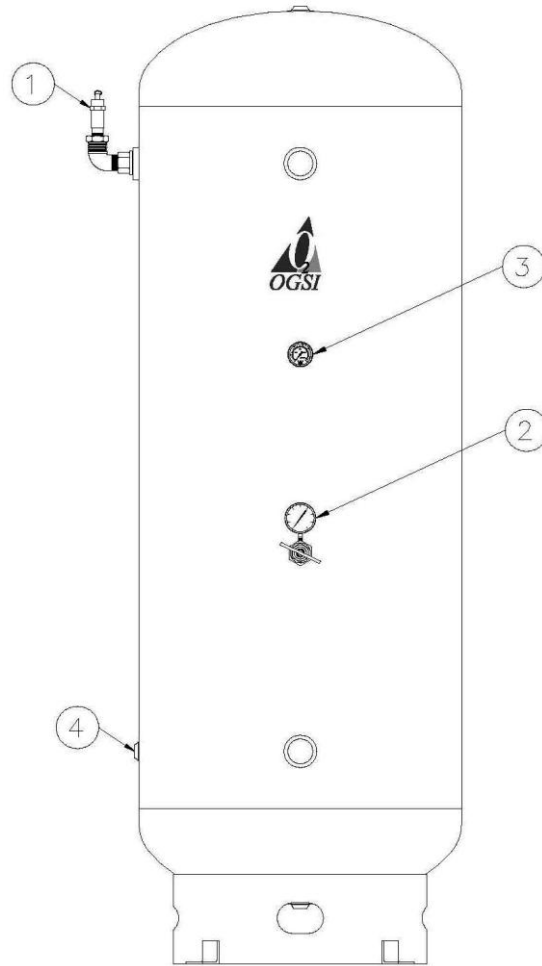

1. Safety Relief Valve
2. Oxygen Regulator
3. Oxygen Pressure Gauge
4. Inlet Port

External Components Description

OFF/CONTINUOUS/AUTO Selector Switch	<p>The control switch is used to run the oxygen generator and select the mode of operation desired. Naturally, in the OFF position, there is no power to the unit and the light inside the switch remains turned off.</p> <p>When the switch is turned one position clockwise, the CONTINUOUS mode is selected and the unit will cycle regardless of whether or not oxygen is being drawn from the storage tank. The light inside the switch will glow as well. The advantage of operating in this mode is that oxygen will be available at a slightly higher pressure than in the „AUTO’ mode. The pressure level depends on the demand for oxygen. The disadvantage to operating in this mode is that your compressor will be used more.</p> <p>Turning the switch further clockwise places the generator in the „AUTO’ mode. In this mode, a pressure switch is engaged to sense the oxygen storage tank pressure. Once that pressure reaches about 60 psi (4.1 bar), the generator will stop cycling. When the pressure in the storage tank falls to about 45 psi (3.1 bar), the generator will begin to cycle again attempting to refill the storage tank. While in this mode, the light inside the control switch will glow whenever the unit is cycling.</p>
Feed Air Pressure Gauge	<p>This gauge indicates the pressure of the air supplied to the sieve beds after it has been regulated and filtered. While the generator is cycling, this gauge should vary between 35 psi (2.4 bar) and 70 psi (4.8 bar).</p>
Oxygen Pressure Gauge	<p>This gauge indicates the pressure of oxygen in the storage tank. While this level can vary between 0 psi and 65 psi (4.5 bar), it should remain between 40 psi (2.8 bar) and 65 psi (4.5 bar) during normal operation, except when the unit is started and it needs to fill the storage tank which takes a few minutes.</p>

<p>Oxygen Outlet</p>	<p>The oxygen outlet connection is on the right hand side of the machine. There is an appropriately sized fitting to which the green interconnecting oxygen hose assembly should be attached. This oxygen hose assembly has a female threaded fitting that swivels on each end of it. The other side of this oxygen hose assembly should be connected to the inlet fitting of the oxygen storage tank. If the storage tank was purchased from OGSI, it will have an appropriately sized fitting in place for this connection. If the tank was not purchased from OGSI, you must ensure that it has the appropriate size fitting to accept the hose assembly.</p>
<p>Hours Meter</p>	<p>The hours meter shows how long the unit has been operating. This helps indicate when service intervals are due.</p>
<p>Manual Filter Drain Button</p>	<p>The manual filter drain button can be used at any time to empty the contents of the filter bowl and is especially useful during the filter element replacement procedure. It is a momentary button so it will only hold the drain valve open as long as it is pressed. Upon release, it returns the valve to its normally closed position.</p>
<p>Feed Air Inlet</p>	<p>This inlet is used to supply the feed air to the oxygen generator. It is located on the left side of the machine as you face it. A hose or pipe should be attached to this fitting. It should be of adequate diameter to supply air at a sufficient pressure and flow rate to feed the generator. OGSI can assist in sizing this line.</p>
<p>Filter Drain Tubing</p>	<p>A small hose is provided with each unit and can be run directly into a drain. This hose will prevent water and material trapped by the filter from being blown directly on to the floor. Using this hose/connection is strictly up to the user.</p>

<p>Safety Relief Valve</p>	<p>This valve is in place to ensure that the oxygen sieve tank does not exceed maximum pressure. It will only open in the event of a serious malfunction. It is connected to the same tee fitting to which the interconnecting oxygen hose is attached.</p>
<p>Power Cord</p>	<p>The power cord is designed for use on 115 VAC/60 Hz electrical systems and comes with a three-pronged ground fault protected plug. For 230 VAC, a plug of local configuration will need to be installed by the end-user.</p>
<p>Oxygen Regulator</p>	<p>If your storage tank came from OGSI, there will be an oxygen regulator, which should be attached to it. It can be used to set the regulated oxygen pressure out of the storage tank at any level up to 60 psi (4.1 bar). Please keep in mind that our specification for the maximum oxygen pressure available from a system is 45 psi (3.1 bar). Pressures higher than 45 psi (3.1 bar) will only be available for short periods of time if oxygen is drawn from the storage tank at or above the specified production rates for the machines. If the demand is for a higher pressure but a lower flow rate, or only for a short period of time, the maximum pressure allowed is up to 60 psi (4.1 bar).</p>

Internal Components

OG-375/OG-500/OG-650

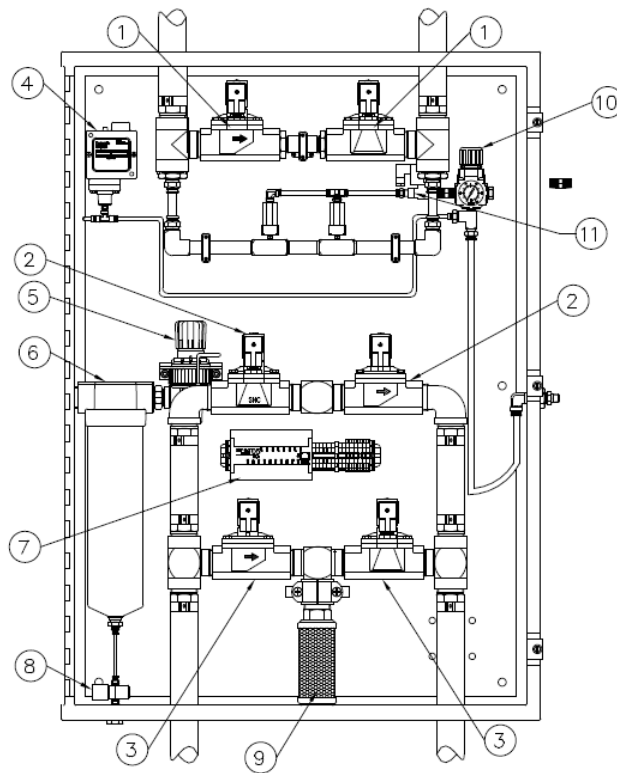

1. Equalization Valves

2. Feed Valves

3. Waste Valves

4. Pressure Switch

5. Pressure Regulator

6. Filter

7. PLC

8. Filter Drain Valve

9. Exhaust Muffler

10. Back Pressure Regulator

11. Oxygen Outlet Valve

OG-750/OG-1000

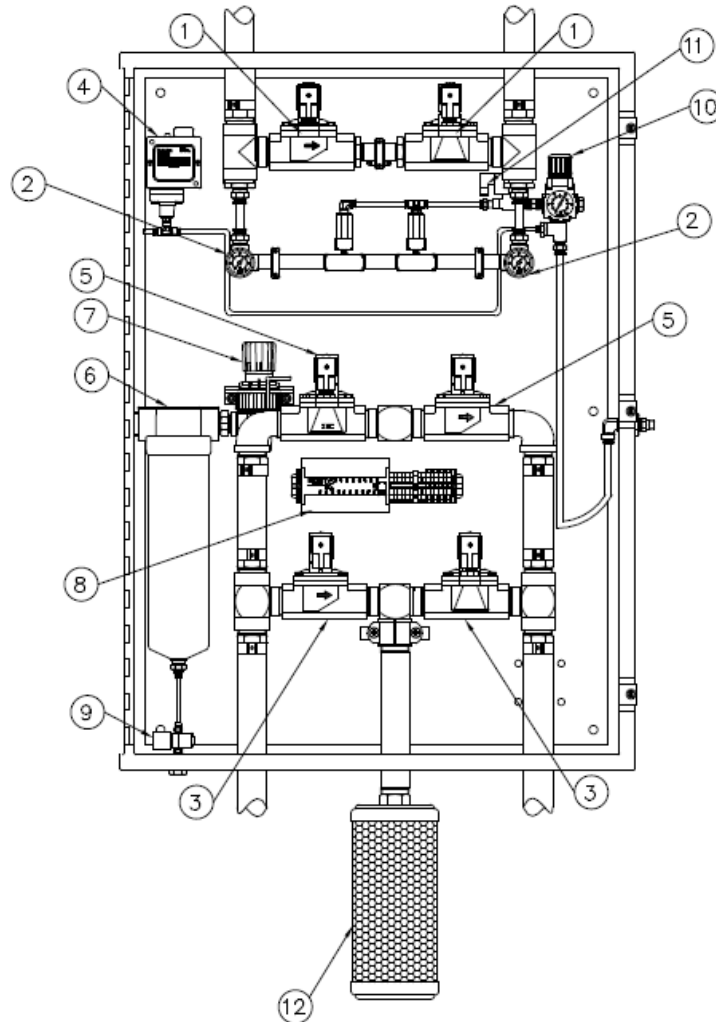

1. Equalization Valves

2. Equalization Pressure Gauges

3. Waste Valves

4. Pressure Switch

5. Feed Valves

6. Filter

7. Feed Air Pressure Regulator

8. PLC

9. Filter Drain Valve

10. Back Pressure Regulator

11. Oxygen Outlet Valve

12. Exhaust Muffler

OG-1250

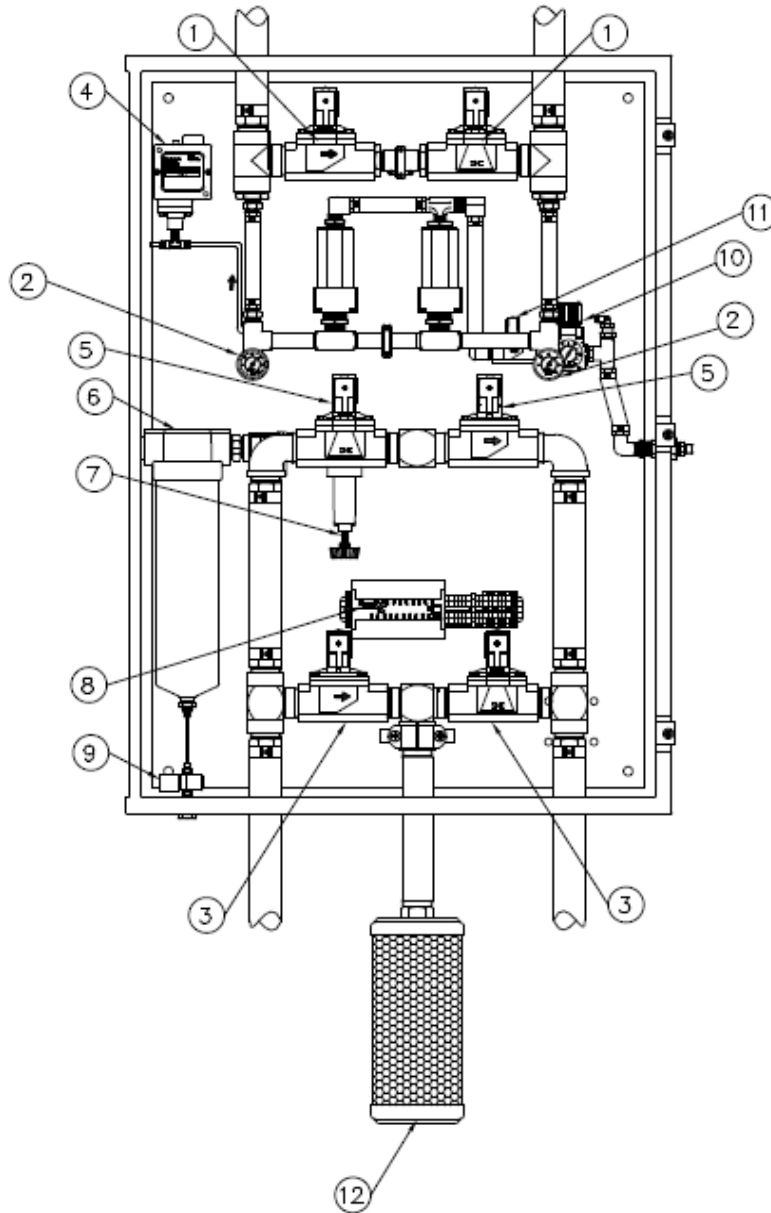

1. Equalization Valves

2. Equalization Pressure Gauges

3. Waste Valves

4. Pressure Switch

5. Feed Valves

6. Filter

7. Feed Air Pressure Regulator

8. PLC

9. Filter Drain Valve

10. Back Pressure Regulator

11. Oxygen Outlet Valve

12. Exhaust Muffler

Internal Components Description

<p>Equalization Valves</p>	<p>The equalization valves allow gas to pass between the beds at the end of each pressurization cycle in order to increase the efficiency of the machine by reducing the amount of air needed to produce oxygen.</p>
<p>Feed Valves A & B</p>	<p>The feed valves allow air to enter the machine and pressurize the beds beginning the air separation/oxygen generation process. Only one of these valves is open at any point in time.</p>
<p>Waste Valves A & B</p>	<p>The waste valves allow the nitrogen gas that has been trapped in the previous adsorption cycle to be discharged back to the air. As with the feed valves, only one of these valves will be open at a time. They operate in conjunction with the opposite feed valve. For example, when the feed valve A is open, the waste valve B will open simultaneously. The reverse is also true.</p>
<p>Pressure Switch</p>	<p>The pressure switch is a sensor that tells the PLC if the pressure of the oxygen storage tank has built up to the preset limit.</p>
<p>Back Pressure Regulator</p>	<p>The back pressure regulator controls the pressure of the oxygen being delivered from the machine. Turning the regulator knob clockwise increases the pressure and decreases the flow rate of the oxygen, which in turn, raises the purity of the oxygen delivered. Turning the knob counter-clockwise decreases the pressure and increases the flow; however the purity level decreases. This should be set around 70 psi (4.8 bar).</p>
<p>Filter</p>	<p>The filter keeps dust, dirt and moisture from entering the sieve beds and damaging the sieve.</p>
<p>PLC</p>	<p>The PLC (Programmable Logic Controller) processes inputs and outputs to and from system components, and communicates with the touchscreen. This is the brain of the machine.</p>

<p>Filter Drain Valve</p>	<p>This valve allows condensate and waste material trapped in the filter to be discharged automatically at fixed intervals by the PLC or by pressing the manual filter drain button at any time.</p>
<p>Exhaust Muffler</p>	<p>The exhaust muffler is used to silence the exhaust noise that occurs as a result of the sieve beds rapidly depressurizing to atmospheric pressure, releasing nitrogen. For installations where a lower noise level is required, OGSI offers an optional alternative muffler system that can decrease the emitted noise even further.</p>
<p>Oxygen Outlet Valve</p>	<p>This valve restricts the flow of oxygen from the machine during the cycle to optimize oxygen output.</p>
<p>Equalization Pressure Gauges <i>(For OG-750 and above)</i></p>	<p>These gauges measure the pressure of the gas as the two sieve beds prepare for the next cycle. These gauges are troubleshooting indicators in larger systems. During normal operation, while one gauge is increasing, the other is decreasing.</p>
<p>Feed Air Pressure Regulator</p>	<p>This feature manually controls the air pressure going into the oxygen generator tank. This should be set around 70 psi (4.8 bar). The delivery pressure increases when the regulator is turned clockwise and decreases when the regulator is turned counter-clockwise.</p>

Process Flow Schematic

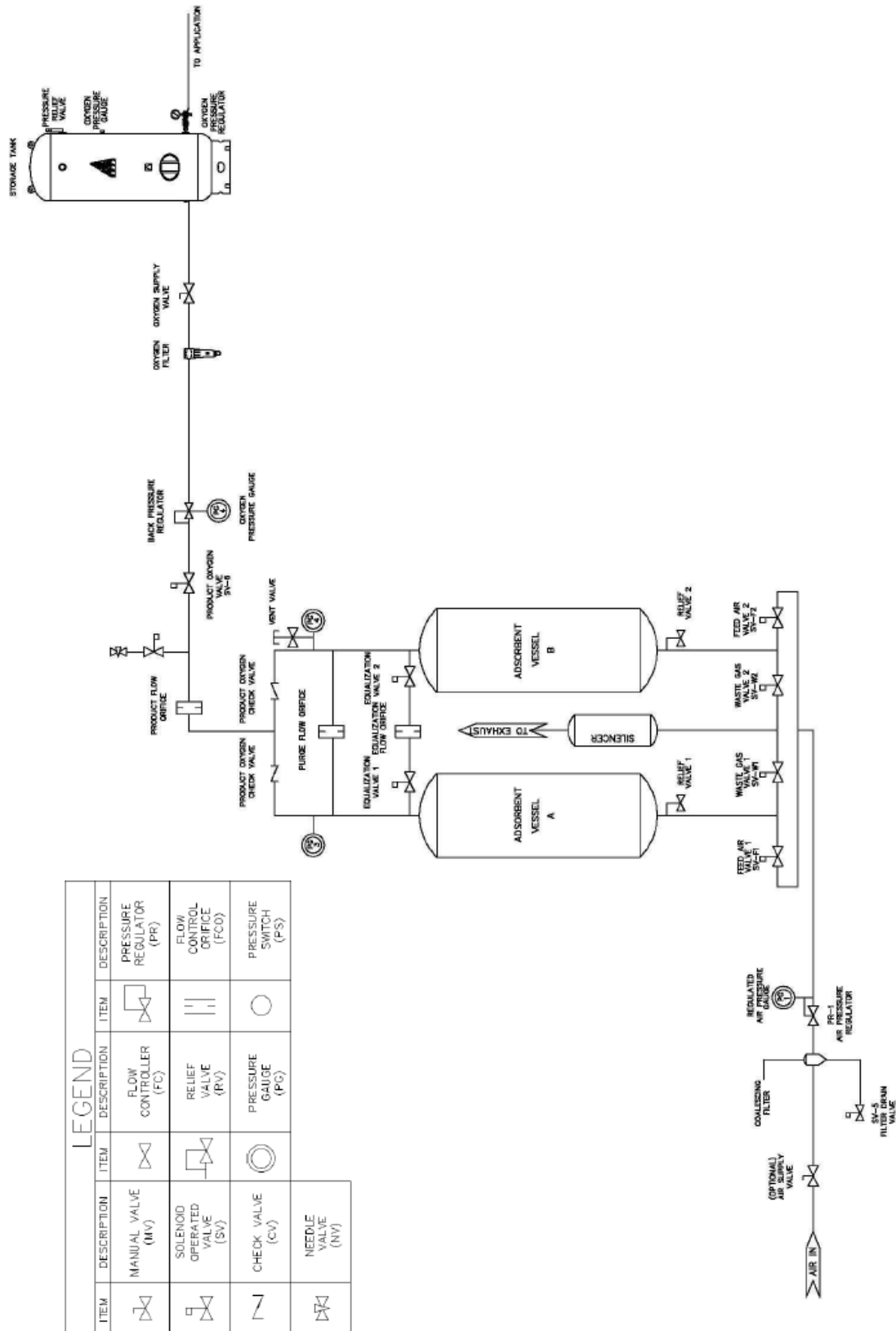

LEGEND			
ITEM	DESCRIPTION	ITEM	DESCRIPTION
	MANUAL VALVE (MV)		FLOW CONTROLLER (FC)
	SOLENOID OPERATED VALVE (SV)		RELIEF VALVE (RV)
	CHECK VALVE (CV)		PRESSURE GAUGE (PG)
	NEEDLE VALVE (NV)		PRESSURE SWITCH (PS)

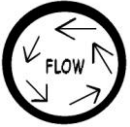

Process Flow Description

The normal flow of air through the **OG-375** through **OG-1250** units is shown on the previous page in the Process Flow Schematic. Once the incoming air is filtered and compressed in the **OG-375** through **OG-1250** units, it is directed into one of the two sieve beds. As the air enters the bed, the nitrogen is adsorbed by the sieve and the oxygen passes through as product gas to the mixing tank. Each bed produces oxygen until the sieve in that bed is saturated with nitrogen. When this occurs, the feed airflow is directed to the other bed, which continues the production process. While the second bed is producing oxygen, the first bed is releasing into the atmosphere the nitrogen it adsorbed, under very low pressure through a waste gas muffler.

The rated production capacities of these machines are as follows:

OG-375 (375 SCFH or 177 LPM or 10 Nm³/h)

OG-500 (500 SCFH or 236 LPM or 13 Nm³/h)

OG-650 (650 SCFH or 307 LPM or 17 Nm³/h)

OG-750 (750 SCFH or 354 LPM or 20 Nm³/h)

OG-1000 (1000 SCFH or 472 LPM or 26 Nm³/h)

OG-1250 (1250 SCFH or 589 LPM or 33 Nm³/h)

If a higher flow rate is drawn from the machine, the delivery pressure will fall while at higher delivery pressures, the flow rates available will decrease. Oxygen purity will also suffer in any overdraw conditions.

Set-up Diagrams

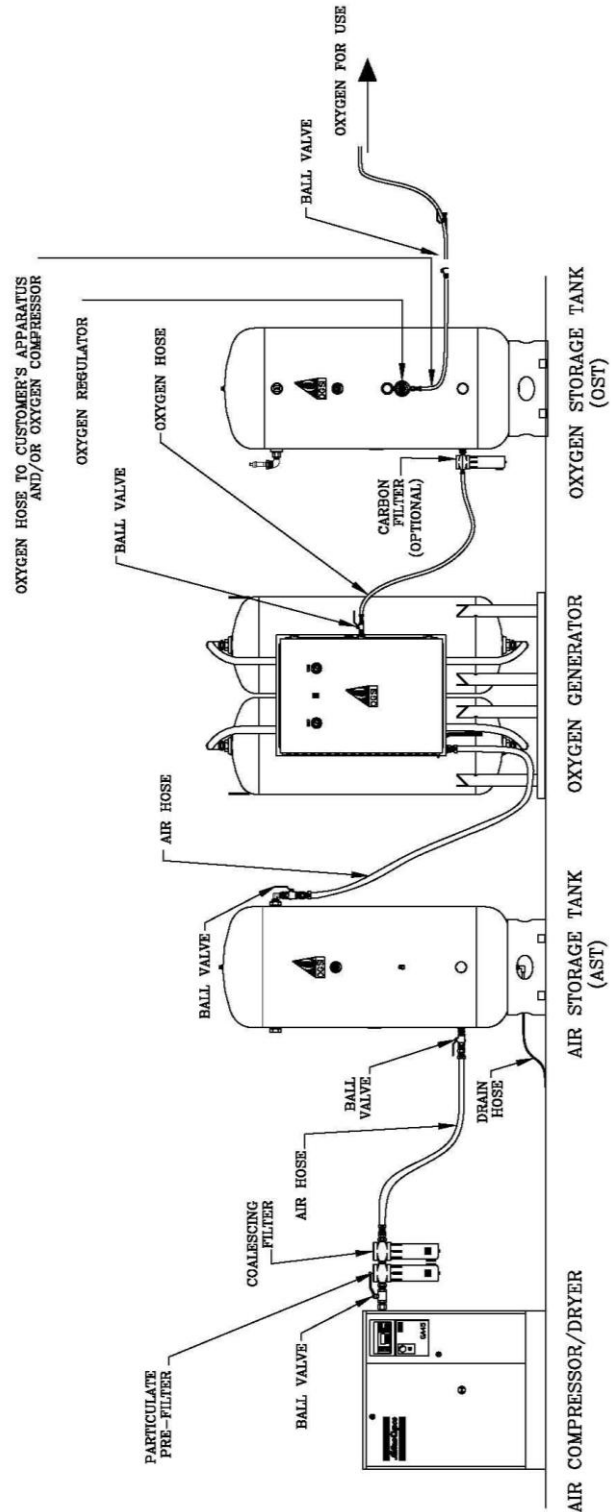

Occasionally, a user may choose to maintain a liquid or cylinder backup and keep it connected to his system for crucial applications. This is a precaution that ensures uninterrupted oxygen flow in case of loss of power supply and/or during compressor or generator service.

Switch Connection Diagram

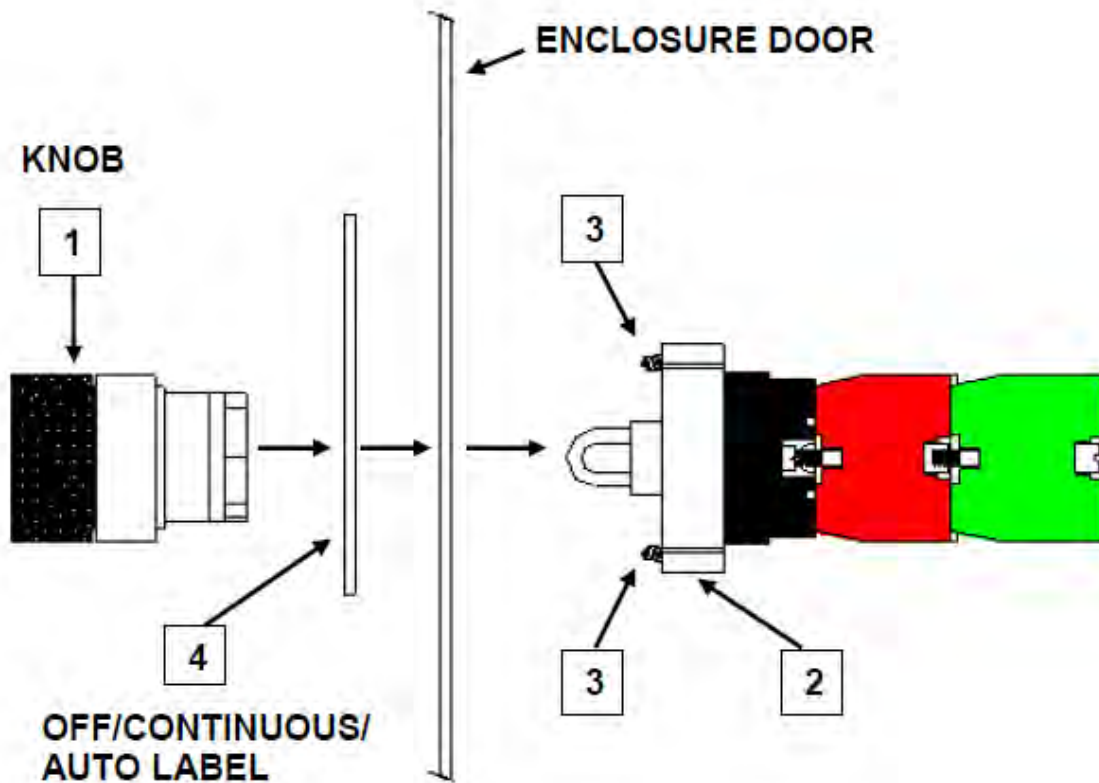

Assembly Instructions:

1. Take # 1 and push through # 4.
2. Take # 1 and # 4 and push through the front of the enclosure door.
3. Push # 2 onto # 1 and # 4 and turn it to lock them together.
4. Ensure that the assembled parts are straight and tighten both # 3s using a screwdriver.

Unit Specifications

Performance

Oxygen Volume	
▪ <i>OG-375</i>	375 SCFH @ 45 psi or 10 Nm ³ /h @ 3.1 bar
▪ <i>OG-500</i>	500 SCFH @ 45 psi or 13 Nm ³ /h @ 3.1 bar
▪ <i>OG-650</i>	650 SCFH @ 45 psi or 17 Nm ³ /h @ 3.1 bar
▪ <i>OG-750</i>	750 SCFH @ 45 psi or 20 Nm ³ /h @ 3.1 bar
▪ <i>OG-1000</i>	1000 SCFH @ 45 psi or 26 Nm ³ /h @ 3.1 bar
▪ <i>OG-1250</i>	1250 SCFH @ 45 psi or 33 Nm ³ /h @ 3.1 bar
Oxygen Pressure	
▪ <i>OG-375 through OG-1250</i>	1-60 psi (4.1 bar)
Oxygen Purity	93% (± 3%) [United States Pharmacopeia (USP) XXII oxygen 93% Monograph]
Oxygen Dew Point	- 60°F (-51°C)
Feed Air Requirement (Incoming)	
▪ <i>OG-375</i>	68 SCFM @ 90 psi (107 Nm ³ /h @ 3.1 bar)
▪ <i>OG-500</i>	88 SCFM @ 90 psi (139 Nm ³ /h @ 3.1 bar)
▪ <i>OG-650</i>	118 SCFM @ 90 psi (186 Nm ³ /h @ 3.1 bar)
▪ <i>OG-750</i>	133 SCFM @ 90 psi (210 Nm ³ /h @ 3.1 bar)
▪ <i>OG-1000</i>	175 SCFM @ 90 psi (276 Nm ³ /h @ 3.1 bar)
▪ <i>OG-1250</i>	225 SCFM @ 90 psi (355 Nm ³ /h @ 3.1 bar)
Response Time	Approximately 5 minutes to attain maximum purity after initial start-up or extended shut-down

Continued

Physical

Oxygen Outlet Fitting	B Size oxygen adapter
Air Inlet Fitting	
<ul style="list-style-type: none"> ▪ OG-375 ▪ OG-500 ▪ OG-650 ▪ OG-750 ▪ OG-1000 ▪ OG-1250 	<ul style="list-style-type: none"> $\frac{3}{8}$" FNPT Bulkhead $\frac{3}{8}$" FNPT Bulkhead $\frac{3}{8}$" FNPT Bulkhead $\frac{1}{2}$" FNPT Bulkhead $\frac{1}{2}$" FNPT Bulkhead $\frac{3}{4}$" FNPT Bulkhead
Sound Level	
<ul style="list-style-type: none"> ▪ OG-375 ▪ OG-500 ▪ OG-650 ▪ OG-750 ▪ OG-1000 ▪ OG-1250 	<ul style="list-style-type: none"> 70 dBA @ 1 m 70 dBA @ 1 m 70 dBA @ 1 m 70 dBA @ 1 m 70 dBA @ 1 m 70 dBA @ 1 m
Dimensions	
<ul style="list-style-type: none"> ▪ OG-375 	<ul style="list-style-type: none"> 36 x 30 x 84 in (W x D x H) 76 x 91 x 213 cm (W x D x H)
<ul style="list-style-type: none"> ▪ OG-500 	<ul style="list-style-type: none"> 45 x 36 x 89 in (W x D x H) 114 x 96 x 226 cm (W x D x H)
<ul style="list-style-type: none"> ▪ OG-650 	<ul style="list-style-type: none"> 55 x 44 x 84 in (W x D x H) 140 x 112 x 213 cm (W x D x H)
<ul style="list-style-type: none"> ▪ OG-750 	<ul style="list-style-type: none"> 55 x 48 x 91 in (W x D x H) 140 x 122 x 231 cm (W x D x H)
<ul style="list-style-type: none"> ▪ OG-1000 	<ul style="list-style-type: none"> 55 x 48 x 121 in (W x D x H) 140 x 122 x 307 cm (W x D x H)
<ul style="list-style-type: none"> ▪ OG-1250 	<ul style="list-style-type: none"> 60 x 50 x 128 in (W x D x H) 173 x 132 x 279 cm (W x D x H)

Weight	OG-375 – 1350 lb (612 kg) OG-500 – 2250 lb (1021 kg) OG-650 – 2500 lb (1134 kg) OG-750 – 3150 lb (1429 kg) OG-1000 – 4550 lb (2064 kg) OG-1250 – 5600 lb (2540 kg)
<u>Power Requirement</u>	
<i>OG-375</i> <ul style="list-style-type: none"> ▪ Standard (Domestic) ▪ Optional (International) 	115 VAC, 60 Hz, Single Phase, 1 A 230 VAC, 50/60 Hz, Single Phase, 0.5 A
<i>OG-500</i> <ul style="list-style-type: none"> ▪ Standard (Domestic) ▪ Optional (International) 	115 VAC, 60 Hz, Single Phase, 1 A 230 VAC, 50/60 Hz, Single Phase, 0.5 A
<i>OG-650</i> <ul style="list-style-type: none"> ▪ Standard (Domestic) ▪ Optional (International) 	115 VAC, 60 Hz, Single Phase, 1 A 230 VAC, 50/60 Hz, Single Phase, 0.5 A
<i>OG-750</i> <ul style="list-style-type: none"> ▪ Standard (Domestic) ▪ Optional (International) 	115 VAC, 60 Hz, Single Phase, 1 A 230 VAC, 50/60 Hz, Single Phase, 0.5 A
<i>OG-1000</i> <ul style="list-style-type: none"> ▪ Standard (Domestic) ▪ Optional (International) 	115 VAC, 60 Hz, Single Phase, 1 A 230 VAC, 50/60 Hz, Single Phase, 0.5 A
<i>OG-1250</i> <ul style="list-style-type: none"> ▪ Standard (Domestic) ▪ Optional (International) 	115 VAC, 60 Hz, Single Phase, 1 A 230 VAC, 50/60 Hz, Single Phase, 0.5 A

Safety Precautions



It is very important that you read the precautions below and make yourself aware of the hazards of oxygen in general. While it can be handled and used very safely, it can also be mishandled or applied incorrectly causing dangerous situations.



Oxygen is a fire hazard. It can be very dangerous as it vigorously accelerates the burning of combustible materials. To avoid a fire and/or the possibilities of an explosion; oil, grease or any other easily combustible materials must not be used on or near the oxygen generator. **DO NOT SMOKE NEAR THE UNIT.** The unit should be kept away from heat and open flames. Individuals who have experience handling oxygen systems should become the designated operators of the oxygen generator within your facility.



In crucial applications, it is important to have a backup supply of oxygen since the generator does not come with any reserve storage tank and requires electrical power to operate. ***Therefore, during power outages, oxygen will not be produced.***

Do not use extension cords to bring power to the generator. It is also important to use only a properly grounded electrical outlet.

High pressure oxygen may present a hazard. Always follow proper operating procedures, and ***open valves slowly.*** Rapid pressurization may result in operator/user injury. Safety glasses and hearing protection are required when venting oxygen under high pressure.

Ensure that the oxygen outlet stream is not directed toward anyone's clothing. Oxygen will embed itself in the material and one spark or hot ash from a cigarette could violently ignite the clothing.



Pre-Installation

Before installing the **OGSI** Oxygen Generator, it is necessary to consider the location, space available and power supply for the generator.

1) Locating the OG-375 through OG-1250 units:

- The oxygen generator should be located in an area that is indoors and remains between **40°F (5°C)** and **100°F (38°C)**. **Setting up the machine outdoors or in an area that is not normally within this temperature range will void the *OGSI* Warranty.**
- The machine must be located within reach of an air supply line, as this machine requires an external pre-existing source of pressurized air.

2) Power Supply for the OG-375 through OG-1250 units:

- The oxygen generator should be positioned within **8 ft (2.2 m)** of the electrical outlet that will power it. The **OG-375** through **OG-1250** models are stationary units and should not be powered by extension cords exposed to wear. The electrical outlet system to which the **OGSI** oxygen generator is connected should be used exclusively for that purpose and no other electrical appliances should be connected to it.

3) Repacking sieve beds for the OG-375 through OG-1250 units:

- Sieve settles during shipment, therefore it is important to repack the supplied sieve to the top of the sieve beds and ensure that no empty spaces are left in the beds. The sieve can be harmed by exposure to air and caution must be taken to keep the sieve in the oxygen generator and the container sealed as much as possible. *(See pages 33-34 for details on repacking sieve beds.)*

4) Switch for the OG-375 through OG-1250 units:

- The **ON/CONTINUOUS/AUTO** switch is not attached to the unit during shipment. It will need to be attached to the enclosure door before operating the unit. *(See page 25 for switch diagram and instructions to attach it.)*



Required Operating Conditions

Location of Machine:

This standard oxygen generating system is intended for use indoors. The enclosure meets **NEMA 12** protection guidelines, which provides a degree of protection against dust, falling dirt and non-corrosive liquids. A **NEMA 4X** enclosure package is optionally available if outdoor location is required. The **NEMA 4X** package will provide a degree of protection against corrosion, windblown dust and rain and splashing or hose-directed water.

Feed Air/Ambient Air Quality:

The life of any PSA oxygen generator is directly related to the air quality that is fed into it. Hot, humid, dirty, oily air deteriorates and degrades the performance of the molecular sieve. In order to preserve the effectiveness and extend the life of the oxygen generator, precautions must be taken to ensure that the air provided is cool, dry, clean and oil-free. Changing the inlet air filter is a simple and easy way to provide the unit with some protection. It is advisable to operate the unit in an air-conditioned or a well-ventilated area. The room should also be free of toxic gases and high concentrations of hydrocarbons, especially carbon monoxide. Humid, oily areas should be avoided as installation sites as much as possible.

Ambient Air Temperature:

The machine is designed for use over a temperature range of **40°F to 100°F (5°C to 38°C)**. Since hot air has the ability to hold more water in the form of humidity than cool air, operating the unit in hot areas will reduce the effective life of the molecular sieve.

Note: Operation outside of this temperature range will not be warranted by *OGSI*.

Electrical Power:

On U.S. models, the power for the control circuitry of the oxygen generator is a single-phase electrical supply of **115 VAC** and about **1 A** at a frequency of **60 Hz**. This equates to approximately **115 W** of power. On export models, the power for the control circuitry of the oxygen generator is a single phase electrical supply of **230 VAC** and less than **0.5 A** at a frequency of **50 Hz**. This equates to approximately **115 W** of power. Additionally, the unit must be connected to this circuit using only the supplied power cord, and without the use of additional extension cords.

Feed Air Requirements:

The pressure of the incoming feed air supply should be at least **90 psi (6.2 bar)**. Pressure below this level will not allow the machine to run at the oxygen purity, production capacity and efficiency levels it was designed to meet. The compressed air that is fed into the oxygen generator should not be hotter than **100 °F (38 °C)**.

Air temperatures higher than this will immediately reduce the efficiency of the machine and can damage the molecular sieve over time. Hot air is also able to hold much more water than cool air. The use of after coolers on feed air compressors and refrigerated air dryers between the air compressor and the oxygen generator is highly recommended and will improve the performance and life of the oxygen generator.

Pipe scale, oil carryover from the compressor and water vapor should all be minimized to ensure long and trouble-free oxygen generator operation. This can be accomplished with a few regular procedures. It is important to recognize that the air compressor is a crucial component in the oxygen generating process. It needs to be maintained in accordance with the instructions provided in the operating manual. Condensation needs to be blown out (removed) from the air storage tank and air distribution lines at regular intervals to keep it from flowing into the generator. The filter element inside the oxygen generator needs to be replaced every six months. It is recommended that the filter meet the requirements of *ISO8573.1 Class 1.4.1*.

Positioning:

The unit must be operated in an upright position only, with no obstruction in the airflow around the unit.

Sieve Repacking Instructions

This operation is occasionally necessary due to sieve settling during shipment and settling during normal cycling operations.

Approximate Time Required for this Task: 30 minutes/tank

Tools:

- Large Adjustable Wrench
- Funnel
- Molecular Sieve
- Tube Teflon Pipe Dope (1)

The sieve is very sensitive to moisture in the air and will become contaminated if left exposed to air for more than a few minutes.

Procedure:

- 1. VERY IMPORTANT! The oxygen generator must be completely de-pressurized before starting work.** Isolate or de-pressurize the air storage tank (the oxygen storage tank can be left pressurized). Run the oxygen generator in the **CONTINUOUS** mode until all pressure in the sieve beds has been released. Sieve bed pressure can be monitored by the feed air pressure gauge located on the box door (left side gauge). On some models this gauge will be located directly on the air filter/regulator inside the box.
- 2.** Turn the oxygen generator off, and disconnect the power cord. If the generator is hard wired, pull fuse from din rail connection.
- 3.** Remove the view port or plug from the fill port (see drawing on next page). Air will continue to escape slowly so wait until all the air has escaped. Place the funnel into the open port. Open the bucket containing the molecular sieve and pour the molecular sieve into the funnel. Direct the flow of the sieve away from the center of the tank and use the wrench handle gently to move the sieve out to the sides and around the top screen of the tank.
- 4.** After filling in the sides with the sieve, keep adding the molecular sieve so as not to leave any open space at the top. The sieve should come up half way into the fill port's neck.
- 5.** Apply pipe dope liberally to the threads of the plug for the fill port. Install and tighten.
- 6.** Repeat the above steps for the other sieve tank.

Repacking Sieve Beds

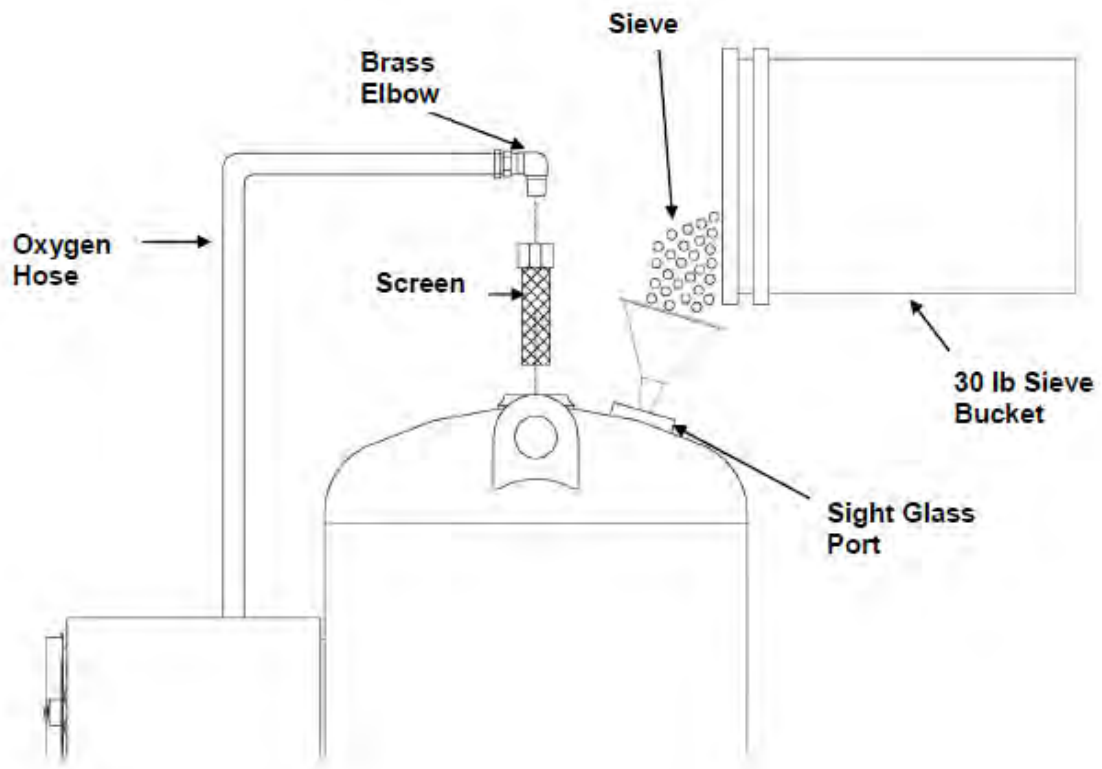



Set-up & Installation

The following instructions are intended as a general guideline for a typical system installation. If you feel that you have an unusual situation or would like additional assistance in determining the appropriateness of a particular set-up, please contact OGSi. (*Refer to Technical Service Assistance on page 42 for contact information.*)

1. Connect a ball valve between the air storage tank (outlet) and the feed air hose (black) provided. This valve is used to shut off the air supply to the generator for filter replacement. If you do not have a valve on hand at this time, skip this step as the valve can be installed at a later date. On tanks supplied by **OGSi**, this valve is included.

OGSi stocks valves that can be used for this purpose. If you need one, you can reach our Sales Department at (716) 564-5165.

2. Connect the feed air hose from the air compressor to the air storage tank's ball valve mentioned above or connect the hose to your air supply inlet on the left side of the generator. On systems this size, a hose is not included as installation set-ups vary greatly. The left side of the generator has a fitting that is labeled „AIR IN’. This fitting is either a 37°- flared JIC fitting or a female pipe thread depending on your model. Connections to these fittings are readily available worldwide through the Parker distribution network or from **OGSi**.
3. Unroll and direct the filter drain hose (clear) into a bucket or floor drain (if available). This drain hose is provided with each unit and can be used to alleviate the potential problem of having water and material trapped by the filter blown directly on to the floor. If this hose is not being used, it should be disconnected from the machine and discarded.
4. Connect the generator outlet oxygen hose (green) to the oxygen outlet connection on the right side of the generator and to the oxygen storage tank. The oxygen outlet connection is labeled as „O₂ OUT’ on the unit. The oxygen hose has threaded fittings that swivel on each end of it. Either side can be connected to the generator as the fittings are the same on each end. If your storage tank was purchased from **OGSi**, it will have an appropriate fitting in place for this connection. It will be attached to the same tee fitting that holds the safety relief valve. If the tank was not purchased from **OGSi**, you must ensure that it has the appropriate size fitting to accept this hose assembly.

OGSi can provide these fittings, if necessary.

5. Connect your oxygen storage tank hose to the oxygen pressure regulator on the oxygen storage tank. If you are using an oxygen manifold as in one of the previous drawings, we recommend another ball valve between the hose that is connected to the oxygen regulator and the oxygen manifold. This ball valve can then be used as your

primary supply or shut off valve between the generator and your application. Closing this valve nightly before turning the generator off will ensure that the storage tank is full the next day.

The oxygen hose and ball valve are not included with the generator because the connections used from location to location can vary greatly. We can provide these ball valves and hose assemblies, if required, but intentionally do not include them with every machine so that we may provide you with the best price for the basic package.

6. Connect the electrical cord into an outlet. It is preferred that the outlet used be one that cannot be accidentally turned off. Oxygen generators shipped within North America can be connected to any typical **115 VAC** outlet while those shipped outside North America will typically be wired to accept a single phase **230 VAC** supply. Once connected, thoroughly read the operating instructions on page 37 before operating the machine.



Operating Instructions

Start-up

Before attempting to run the **OG-375** through **OG-1250** units, it is important to check all the connections in the system. Ensure that all connections are tight as leaks will be detrimental to the unit's performance and increase your operating expenses. Also, review the **„Set-up and Installation'** on page 35 before starting the unit.

1. Start your air compressor and allow it to fill its surge tank to at least **90 psi (6.2 bar)** before starting the oxygen generator.
2. Open the ball valve that supplies air to the oxygen generator (if you have one in place) and check the regulated feed air pressure gauge (on the left side of the generator). The regulated feed air pressure gauge should read about **70 psi (4.8 bar)**.
3. Turn the generator control switch to **„CONTINUOUS'** mode. The unit starts running and begins the generation process. For the first 5 seconds, the filter bowl drain will open and condensation or material trapped in the bowl will be blown out the drain valve on the bottom of the cabinet. If after 5 seconds, there is no air blowing through the filter drain, manually depress the filter drain push button on the lower left-hand side of the cabinet until the bowl is completely empty of fluid. This drain will automatically vent for 5 seconds every 15 minutes while the unit is operating. If this is the first time the oxygen generator is being run or it has not run for a few days, the oxygen storage tank will be full of air. Oxygen will fill the tank but since it is being mixed with the air that was trapped in it at the start of operations, the oxygen purity will be less than optimal. This problem is easily corrected and can be avoided in the future if proper shut-down procedures are followed. To correct this, allow the storage tank to reach **50 psi (3.5 bar)**. The gauge on the right side of the machine will indicate oxygen storage tank pressure. This will take only a few minutes depending on the production capacity of the generator and size of the storage tank. Once this pressure is reached, let the oxygen escape from the tank for about 5 minutes or until the storage tank pressure drops to about **40 psi (2.8 bar)**.

Caution: *While letting the oxygen escape from the tank, make sure there is NO smoking or open flame within 10 ft of the generator, do NOT allow the expelled oxygen to come in contact with any clothing.*

After the pressure drops to 40 psi (2.8 bar), the switch can be turned to 'AUTO'.

4. If the storage tank pressure is above **30 psi (2.1 bar)**, the generator switch can be immediately turned to **„AUTO'** mode. This should be the case upon arriving in the morning to a system that was properly shut-down the evening before or after starting up the first time and having emptied the storage tank down to **40 psi (2.8 bar)**. The oxygen generator will now fill the tank to about **60 psi (4.1 bar)** and then remain in a standby mode until the storage tank pressure drops to about **45 psi (3.1 bar)**. It will then begin to cycle again attempting to keep the storage tank pressure between

45 psi (3.1 bar) and **60 psi (4.1 bar)**. While in this „**AUTO**’ mode, the light inside the control switch will be illuminated whenever the unit is cycling.

5. Open the valve that allows oxygen to flow to your manifold or application. This valve, although not included in our standard accessory package, should be in place to ensure a proper shut-down and avoid the possibility of wasting oxygen through an improperly closed valve.
6. If an average oxygen pressure greater than **45 psi (3.1 bar)** is required or demand is at a peak then it would be better to run the oxygen generator in the „**CONTINUOUS**’ mode. Please keep in mind that our specification for the maximum oxygen pressure available from a system is **45 psi (3.1 bar)**. Pressures higher than **45 psi (3.1 bar)** will only be available for short periods of time if oxygen is drawn from the storage tank at or above the specified production rates for the machines. If the demand is for a higher pressure but a lower flow rate, or only for a short period of time, the maximum pressure allowed is up to **60 psi (4.1 bar)**.

***Caution:** If your application involves metal cutting, welding, brazing, etc., we highly recommend the use of flash guard check valves inserted as close to the torch head in the system as possible.*

Shut-down

Following these few simple steps will allow you to avoid having to run the generator while emptying the storage tank every day or every time you want to use it.

1. Close the valve that allows oxygen to flow to your manifold or application - This will keep the storage tank from being depressurized while oxygen is not being used.
2. Allow the oxygen storage tank to pressurize to **40 psi (2.8 bar)** or more and then turn the control switch to „**OFF**’ -This should really only be done if the storage tank is already pressurized to at least **40 psi (2.8 bar)**.

OR

Leave the control switch in the „**AUTO**’ position and allow the generator to cycle until it refills the storage tank to **60 psi (4.1 bar)**.

You will now have oxygen available for use for the next day.

***Note:** When in the ‘**AUTO**’ mode, the generator will take approximately 15 minutes to build up to maximum oxygen purity every time it turns back on, causing the average purity in the storage tank to be lower than the maximum purity, unless you have the auto-purity option.*

Troubleshooting Guide

Problem	Sign	Cause	Solution
Dusting of Sieve Beds	White powder visible in the machine or very high air pressure levels	<ul style="list-style-type: none"> • Contaminated sieve • Moisture in air 	<ul style="list-style-type: none"> • Repack the sieve beds. • Clean valves and mufflers. • Make sure dry air is being fed to the machine.
No Power	Control switch not illuminated	<ul style="list-style-type: none"> • Power cord not connected to electrical outlet • Loose wires 	<ul style="list-style-type: none"> • Ensure that power is available from 115 VAC supply. • Check the fuse to ensure that it is fully installed and blown. • Visually inspect the electrical wiring. Reconnect any loose wires.



Warning Signs

Low Oxygen Pressure	This may be a result of a leak in the system. Use a leak testing solution to locate and repair any air leaks.
The machine has run for 30 minutes and purity has not yet been reached	This may be a result of a leak in the system. Use a leak testing solution to locate and repair any air leaks.
Oxygen purity has fallen below acceptable limits	This may be an indication of a leak within the system. Use a leak testing solution to locate and repair any leaks.

Preventive Maintenance

Filter Element Replacement:

The air filter element provided with the **OG-375** through **OG-1250** units must be replaced every **six** months on an average. This element helps to maintain the quality of the feed air supply and preserve the molecular sieve inside the oxygen generators.

Failure to replace the filter element on schedule will result in the warranty becoming invalid.

Cabinet & Power Cord:

The cabinet and power cord should be occasionally washed down with a sponge or clean rag and some soapy water. Avoid the use of ammonia or other strong chemical based cleaning solvents. This prevents dust and dirt from building up on the machine.

Filter Drain:

Ensure that the filter drain is unblocked and working properly on a daily basis. When the unit first begins to cycle, the filter drain should open for **5** seconds and after that, for **5** second periods once every **15** minutes.

Air Distribution System:

Condensation inside the pipes can be a big problem in locations where air is piped over long runs. To resolve this issue, open the traps and drains regularly (automatically if practical). This prevents the water from reaching the oxygen generator.

Air Compressor:

You should consider your air compressor an important part of your oxygen generating system. You should maintain it in accordance with the instructions provided in its manual. This includes keeping the compressor well-oiled and changing its filter elements regularly.

Valve Replacements:

Valves should last approximately three (3) years at which time rebuild kits should be ordered.

Filter Element Replacement Instructions

1. Place the oxygen generator in the „**CONTINUOUS**’ mode.
2. Close the valve that supplies air to the oxygen generator.
3. Press the manual filter drain button until the regulated air pressure gauge reads **0 psi**.
4. Place the oxygen generator in the „**OFF**’ mode.
5. Open the cabinet door.
6. Disconnect the plastic tube from the brass Prestolok fitting holding it in place. To disconnect the tube from the fitting, the white collar around the tube must be pushed back into the fitting. This releases the tube. It can now be easily pulled out of the fitting. If it is not easy to pull it out of the fitting, the collar of the Prestolok fitting is probably not being pushed back into the fitting hard enough. The tube should come out easily once it is released from the fitting.
7. Remove the filter bowl by turning the bowl counter-clockwise.
8. Carefully remove the bowl from the cabinet.
9. Clean out the inside of the bowl with some soap and water, and dry thoroughly.
10. Remove the existing filter element by pulling on the element.
11. Insert the new filter element.
12. Replace the filter bowl.
13. Reconnect the drain tube.
14. Check to see that the tube has been replaced securely by opening the valve that supplies air to the oxygen generator. If the tube blows out of the fitting, close the valve again and go back to step 13.
15. Close the cabinet door and begin operating, if desired.

Technical Service Assistance

It is our intention to provide complete customer satisfaction. This manual is one way in which we hope to provide you with technical assistance.

If you do not find what you need in this manual or you have other questions about this equipment, please feel free to contact us directly. We look forward to serving your oxygen needs and invite your inquiries. We will respond to you as promptly as possible.

You can reach **OGSI** through the following means:

- **By Telephone (Within the United States and Canada):**
(800) 414-6474 - Our toll free number (Within USA and Canada only)
(716) 564-5165 - Our direct number
- **By Telephone (Outside the United States):**
Your local International Access Code (usually **0** or **00**), followed by
The Country Code for the U.S. which is **(1)**, followed by
Our Area Code and Number **(716) 564-5165**
- **By Automated Voicemail:**
(716) 564-5165
- **By Fax (Within or outside the United States):**
(716) 564-5173
- **By E-Mail or Website:**
ogsimail@ogsi.com
<http://www.ogsi.com>
- **By Mail:**
OGSI
814 Wurlitzer Drive
North Tonawanda, New York 14120 USA
- **By UPS, FedEx or Common Carrier: (Address to return shipments)**
OGSI
814 Wurlitzer Drive
North Tonawanda, New York 14120 USA

*Technical service personnel are available from **8:00 AM to 5:00 PM EST (GMT - 5)**.
We also have a list of Distributors and Authorized Service Agents available upon request.*

Customer Satisfaction Survey

Help us serve you better. Please take our Customer Satisfaction Survey at www.ogsi.com

Appendix

Spare Parts List

OG-375 through OG-1250

Power Cord 10 ft (with 3-Prong Plug)	1890001.001	1
3 A Fuse	1830001.001	1
Hours Meter 115 V	1870002.002	1
Off-Continuous-Auto Switch Assembly (Standard)	1840001.001	1
PLC - DL 05 (Standard)	1810002.001	1
PLC - DL 105 (Optional)	1810002.002	1
Push Button (For Filter Drain)	1840050.001	1
Transformer-Touch Safe-115 VAC/230 VAC	1860002.050	1

OG-375

Replacement Filter Element-DH-025-AO	218D025.001	2
1" Solenoid Valve Rebuild Kit	1518001.J01	2
1/8" Solenoid Valve (Filter Drain)	1510009.B01	1
1" Air Muffler	1700002.J01	1
1/2" SMC Check Valve	1530001.E02	2
Pressure Switch	1900001.002	1
2 1/2", 0-100 psi Dial Gauge	2190003.RC3	2
1 Set Upper Hoses (Inside Box to Tank Tops) - Per Foot	2210001.J03	6
1 Set Lower Hoses (Inside Box to Tank Bottoms) - Per Foot	2210001.J03	8
Hose Clamps for Upper & Lower Hoses	2230001.L01	12
1" Feed Air Hose Assembly 10 ft long (Includes Swivels & Clamps on Each End)	2220005.J10	1
1" Feed Air Hose - Per Foot	2210001.J03	
3/8" Oxygen Hose Assembly 10 ft long (Includes Swivels & Clamps on Each End)	2220021.D10	1
3/8" Oxygen Hose - Per Foot	2210002.D01	
1/2" Green Poly Tubing (Upper Manifold) - Per Foot	2210003.E01	1
1/4" Clear Poly Tubing (Condensate Drain) - Per Foot	2210003.C04	6
5/32" Nylon Tubing (Front Door) - Per Foot	2210003.BB2	3
Molecular Sieve-XP-OG-375	2010002.001	680 lb

OG-500/OG-650

Replacement Filter Element-DH-030-AO	218D030.001	2
1 1/4" Solenoid Valve Rebuild Kit	1519001.K01	2
1/8" Solenoid Valve (Filter Drain)	1510009.B01	1
1 1/4" Air Muffler	1700002.K01	1
1/2" SMC Check Valve	1530001.E02	2
Pressure Switch	1900001.002	1
2 1/2", 0-100 psi Dial Gauge	2190003.RC3	2
1 Set Upper Hoses (Inside Box to Tank Tops) - Per Foot	2210001.K03	7
1 Set Lower Hoses (Inside Box to Tank Bottoms) - Per Foot	2210001.K03	8
Hose Clamp for Upper & Lower Hoses	2230002.N01	8
1" Feed Air Hose Assembly 10 ft long (Includes Swivels & Clamps on Each End)	2221005.J10	1
1" Feed Air Hose - Per Foot	2210001.J03	
3/8" Oxygen Hose Assembly 10 ft long (Includes Swivels & Clamps on Each End)	2220021.D10	1
3/8" Oxygen Hose - Per Foot	2210002.D01	
1/2" Green Poly Tubing (Upper Manifold) - Per Foot	2210003.E01	1
1/4" Clear Poly Tubing (Condensate Drain) - Per Foot	2210003.C04	6
5/32" Nylon Tubing (Filter Drain & Front Door) - Per Foot	2210003.BB2	3
Molecular Sieve-XP-OG500	2010002.001	990 lb
Molecular Sieve-XP-OG650	2010002.001	1350 lb

OG-750

Replacement Filter Element-DH-030-AA	218D030.002	2
1 1/2" Solenoid Valve Rebuild Kit	1519001.L01	2
1/8" Solenoid Valve (Filter Drain)	1510009.B01	1
1 1/2" Air Muffler	1700002.L01	1
3/4" SMC Check Valve	1530001.G02	2
Pressure Switch	1900001.002	1
2 1/2", 0-100 psi Dial Gauge	2190003.RC3	2
1 Set Upper Hoses (Inside Box to Tank Tops) - Per Foot	2210001.L03	10
1 Set Lower Hoses (Inside Box to Tank Bottoms) - Per Foot	2210001.L03	8
Hose Clamp for Upper & Lower Hoses	2230002.R01	8
1" Feed Air Hose Assembly 10 ft long (Includes Swivels & Clamps on Each End)	2220005.J10	1
1" Feed Air Hose - Per Foot	2210001.J03	

1/2" Oxygen Hose Assembly 10 ft long (Includes Swivels & Clamps on Each End)	2220022.E10	1
1/2" Oxygen Hose - Per Foot	2210002.E01	
1/2" Green Poly Tubing (O2 Discharge)- Per Foot	2210003.E01	2
1/4" White Poly Tubing (Filter Drain-Internal) - Per Foot	2210003.C02	3
1/4" Clear Poly Tubing (Condensate Drain) - Per Foot	2210003.C04	6
5/32" Nylon Tubing (Front Door) - Per Foot	2210003.BB2	3
Molecular Sieve-XP-OG-750	2010002.001	1578 lb
<u>OG-1000/OG-1250</u>		
Replacement Filter Element-DH-035-AA	218D035.002	2
1 1/2" Solenoid Valve Rebuild Kit	1519001.L01	2
1/8" Solenoid Valve (Filter Drain)	1510009.B01	1
1 1/2" Air Muffler	1700002.L01	1
3/4" SMC Check Valve	1530001.G02	2
Pressure Switch	1900001.002	1
2 1/2", 0-100 psi Dial Gauge	2190003.RC3	2
1 Set Upper Hoses (Inside Box to Tank Tops) - Per Foot	2210001.L03	10
1 Set Lower Hoses (Inside Box to Tank Bottoms) - Per Foot	2210001.L03	8
Hose Clamp for Upper & Lower Hoses	2230002.R01	8
1" Feed Air Hose Assembly 10 feet long(Includes Swivels & Clamps on Each End)	2220005.J10	1
1" Feed Air Hose - Per Foot	2210001.J03	
1/2" Oxygen Hose Assembly 10 feet long(Includes Swivels & Clamps on Each End)	2220022.E10	1
1/2" Oxygen Hose - Per Foot	2210002.E01	
1/2" Green Poly Tubing (O2 Discharge)- Per Foot	2210003.E01	2
1/4" White Poly Tubing (Filter Drain-Internal) - Per Foot	2210003.C02	3
1/4" Clear Poly Tubing (Condensate Drain) - Per Foot	2210003.C04	6
5/32" Nylon Tubing (Front Door) - Per Foot	2210003.BB2	3
Molecular Sieve-OG1000	2010002.001	2600 lb
Molecular Sieve-OG1250	2010002.001	3000 lb
Manual – Available Free on Website	9000000.008	1

Oxygen Cleaning Procedure

Scope

This procedure sets forth the cleaning requirements for parts that are used in the construction of **OGSI** oxygen systems and are in the gaseous oxygen product stream including but not limited to valves, tubing, fittings, manifolds and pipes.

Objective

The objective of this procedure is to provide personnel with clear directions and an understanding of how parts are to be cleaned and why that is important. This document is based on guidelines provided in publication **CGA G-4.1-2009** which is produced by the Compressed Gas Association (CGA) and is intended to ensure that our internal procedure is compliant with that publication.

Safety

Harmful contamination such as grease, dirt, oil, dust, solvents, weld slag, sand, rust and previously applied thread sealants on parts that come into contact with oxygen can cause a combustion reaction resulting in system degradation or failure or worse, a hazard to nearby personnel. Care needs to be taken in the cleaning and handling of components used in oxygen service to prevent any contamination related failure.

While the **CGA G-4.1-2009** standard makes allowance for cleaning parts using caustic agents, acids or solvents, the **OGSI** procedure will use only mechanical (soaking, wire brushing or grinding) means for pre-cleaning and hot water cleaning with aqueous detergents for final cleaning. This is done to reduce any chemical exposure risk to personnel and to eliminate the additional steps needed to remove these cleaning agents from the parts themselves.

Training

Personnel involved in the cleaning and preparation of parts used in oxygen service should be trained in these cleaning procedures and be familiar with this document.

Process Flow Chart

The flow chart below describes oxygen cleaning and parts handling process.

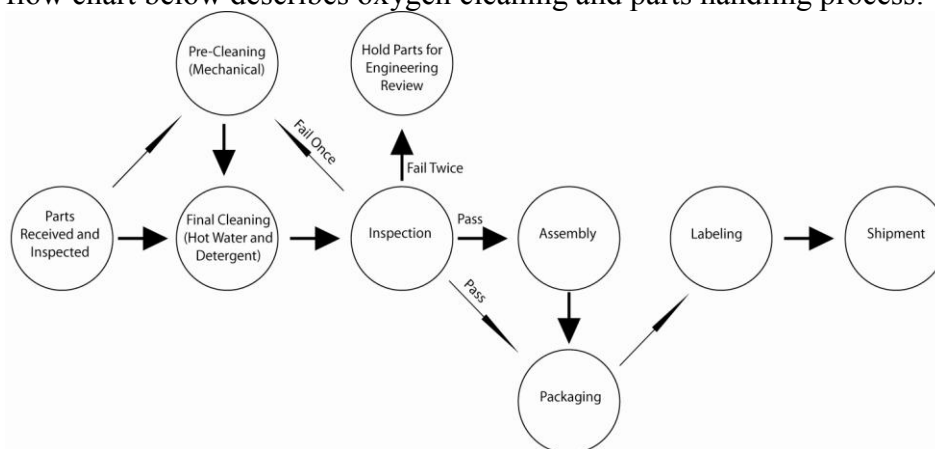

Parts Received and Initial Inspection

Upon determining which parts need to be cleaned, the technician needs to perform an initial visual inspection (under white light). Check for the presence of visible residue on the parts

including but not limited to oil, grease, dirt, dust, rust, weld slag or pre-existing thread sealant among others. For parts that have an internal cavity that is not directly observable by the naked eye, a lint free cloth that is first soaked in water can be inserted into the part and withdrawn for evidence of contamination. No part failing inspection shall be used in any assembly.

Pre-Cleaning

Pre-cleaning methods include soaking parts in a water based solution with an aqueous detergent, using a wire brush or thread pick, holding it under a wire brush grinding wheel or simply wiping it down with a clean rag. Upon completion of pre-cleaning, the part should be clear of any visible contamination and ready for final cleaning.

Final Cleaning

Final cleaning involves placing the parts in the parts washing machine, adding an appropriate amount of detergent and running them through the cleaning cycle. Consideration shall be given to the size, shape and number of parts to be cleaned at one time to ensure that the system is not overloaded or its function impaired. The cleaning temperature inside the washer shall be **120°F (49°C) to 140°F (60°C)** and the detergent to be used shall be Cascade™. This detergent has a flash point above **105°F (41°C)** but it does not sustain combustion and there are no exposure controls for it. Parts can be removed from the washer once the drying cycle is complete.

Inspection

Upon completion of the final cleaning cycle, all parts should be removed from the parts washing machine and inspected for any residual contamination. The item shall be observed to confirm the absence of any contaminants including any oil, grease, detergent, moisture, lint, or other foreign materials. If any material remains on the part after the final cleaning cycle, the part shall be returned for a second round of pre-cleaning and final cleaning.

Packaging

Once a part or assembly has been cleaned for oxygen service, it should be protected to prevent recontamination if it will be put into storage. Small to medium sized parts should be packaged in plastic bags. Larger assemblies should be bubble-wrapped or wrapped in foam material and then moved on to final packaging in boxes and/or crates.

Labeling

Once a part or an assembly has been cleaned and packaged for oxygen service, it should be labeled per the customer's instructions, but at a minimum;

- contain the statement "**Cleaned for Oxygen Service**"
- contain the date of cleaning or packaging

References

The following publications were referenced in the creation of this document.

- CGA G-4.1-2009, *Cleaning Equipment for Oxygen Service*, Compressed Gas Association, Inc., 4221 Walney Road, 5th Floor, Chantilly, VA 20151. www.cganet.com
- *Oxygen Cleaning Procedure* Rev. L (8/05), RIX Industries, Inc., 4900 Industrial Way, Benicia, CA 94510. www.rixindustries.com

Air Changes by Room Size/Machine Size

Air Changes Required in a Room Per Hour for All Models

Model Number	Room Volume in Cubic Feet (ft ³)										
	1000	2000	3000	4000	5000	6000	7000	8000	9000	10000	12500
OG-15	5	2.5	2	1.5	1	1	1	1	1	1	1
OG-20	8	4	2.5	2	2	1.5	1	1	1	1	1
OGS-20	8	4	2.5	2	2	1.5	1	1	1	1	1
OG-25	10	5	4	2.5	2.5	2	1.5	1	1	1	1
OG-50	20	10	7.5	5	5	4	3	2.5	2	2	1.5
OG-100	NR	20	15	10	9	8	7	5	4	4	3
OG-175	NR	25	18	12.5	11	10	8	6	5	5	4
OG-250	NR	30	22.5	15	13	11	9	7.5	7	6	5
OG-375	NR	NR	30	27	22.5	18	15	13	11	8	7
OG-500	NR	NR	NR	30	27	22.5	18	15	13	11	8
OG-650	NR	NR	NR	NR	30	27	22.5	18	15	13	11
OG-750	NR	NR	NR	NR	NR	30	27	22.5	18	16	13
OG-1000	NR	NR	NR	NR	NR	NR	NR	30	26	22	17
OG-1250	NR	NR	NR	NR	NR	NR	NR	NR	NR	30	24
OG-1500	NR	NR	NR	NR	NR	NR	NR	NR	NR	NR	30
CFP-15+/15M	5	2.5	2	1.5	1	1	1	1	1	1	1
MOGS-100	NR	20	15	10	9	8	7	5	4	4	3

Notes:

1. **NR** means that the models indicated are not recommended for rooms of this size.
2. For air changes requirements for models **OG-2000** and above, please contact **OGSI**.

Units of Measurement

lb	U.S. Pound
hp	Horsepower
psi	Pound-force per Square Inch
kW	Kilowatt
ft³	Cubic Feet
VAC	Volts Alternating Current
Hz	Hertz
SCFH	Standard Cubic Foot per Hour
SCFM	Standard Cubic Foot per Minute
LPM	Liter Per Minute
1 bar	1.45 x 10 ¹ psi
dBA	Decibel (A scale)
A	Ampere
W	Watt
°C	Degree Celsius/Centigrade
°F	Degree Fahrenheit

