

SPECS: AST-1550/OST-1550

CAPACITY.....1550 GALLONS (204 CU. FT.)

WEIGHT.....2600 LBS. (1000 kg)

CODE.....ASME Sec. VIII Div 1

DIMENSIONS:

Diameter.....48" (121.92 cm)

Height (w/base).....Approx. 152-1/2" (387.35 cm)

PRESSURE RATING.....150 PSI (TESTED AT 195 PSI)

- FITTING SIZES**.....
- F1=1" NPT FLAT FLANGE
 - F2=1/4" NPT FLAT FLANGE
 - F3=6" ANSI RF.SO. FLANGE
 - F4=1" NPT RADIAL FLANGE
 - F5=1-1/4" NPT FLAT FLANGE
 - F6=1-1/4" NPT RADIAL FLANGE
 - C1=3" NPT HALF COUPLING

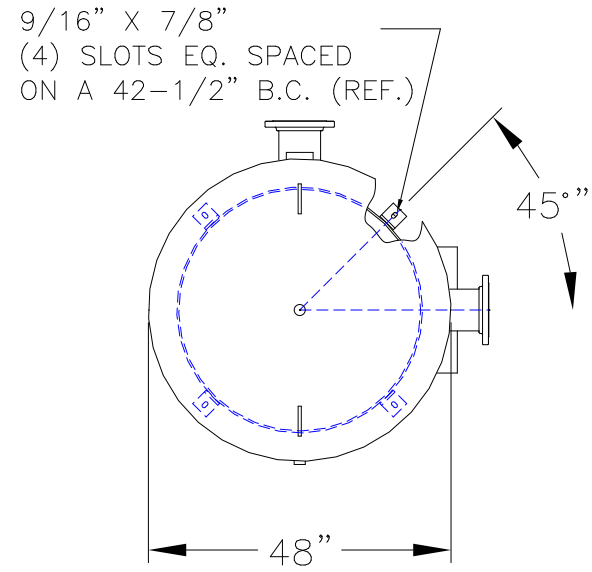
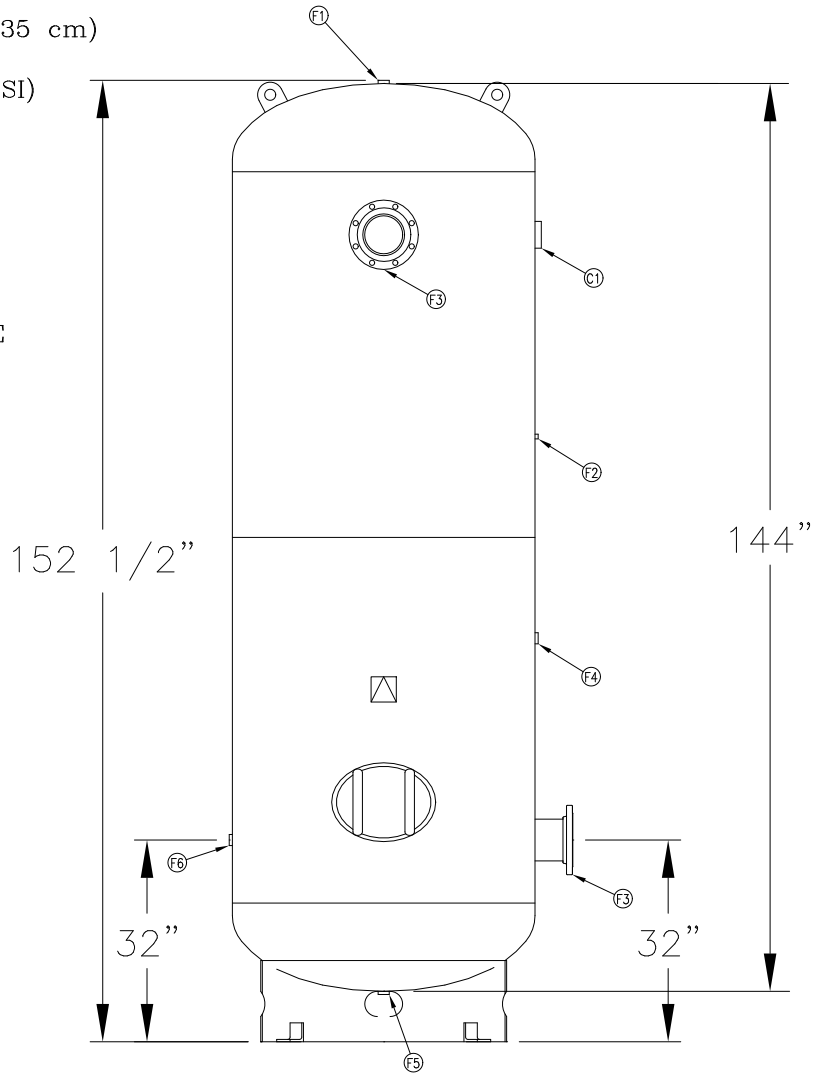

REVISIONS

REV	DESCRIPTION	DATE	CHK	ECN #

OGSI
 814 Wurlitzer Drive
 North Tonawanda, NY 14120
 Phone: (716) 564-5165
 Fax: (716) 564-5173

FILE NAME
 AST_OST-1550
 GEN ARR.

PLOT SCALE
 1 TO 1
 ENGINEER
 J. M. McMAHON

EFFECTIVITY OR SERIAL NO.
 DRAWN BY
 V.CAULEY
 DATE
 08/19/09

PAGE
 1 OF 1

TITLE
 GENERAL
 ARRANGEMENT
 AST_OST-1550