

SPECS: AST-30/OST-30

CAPACITY.....30 GALLONS (4 CU. FT.)

WEIGHT.....85 LBS. (38.25 KG)

CODE.....ASME Sec. VIII Div 1

DIMENSIONS:

Diameter.....16" (40.64 cm)

Height (w/base).....Approx. 41" (105 cm)

PRESSURE RATING.....200 PSI (TESTED AT 260 PSI)

FITTING SIZES.....F1=1/2" NPT
 F2=1-1/2" NPT
 F3=3/4" NPT
 F4=1/4" NPT

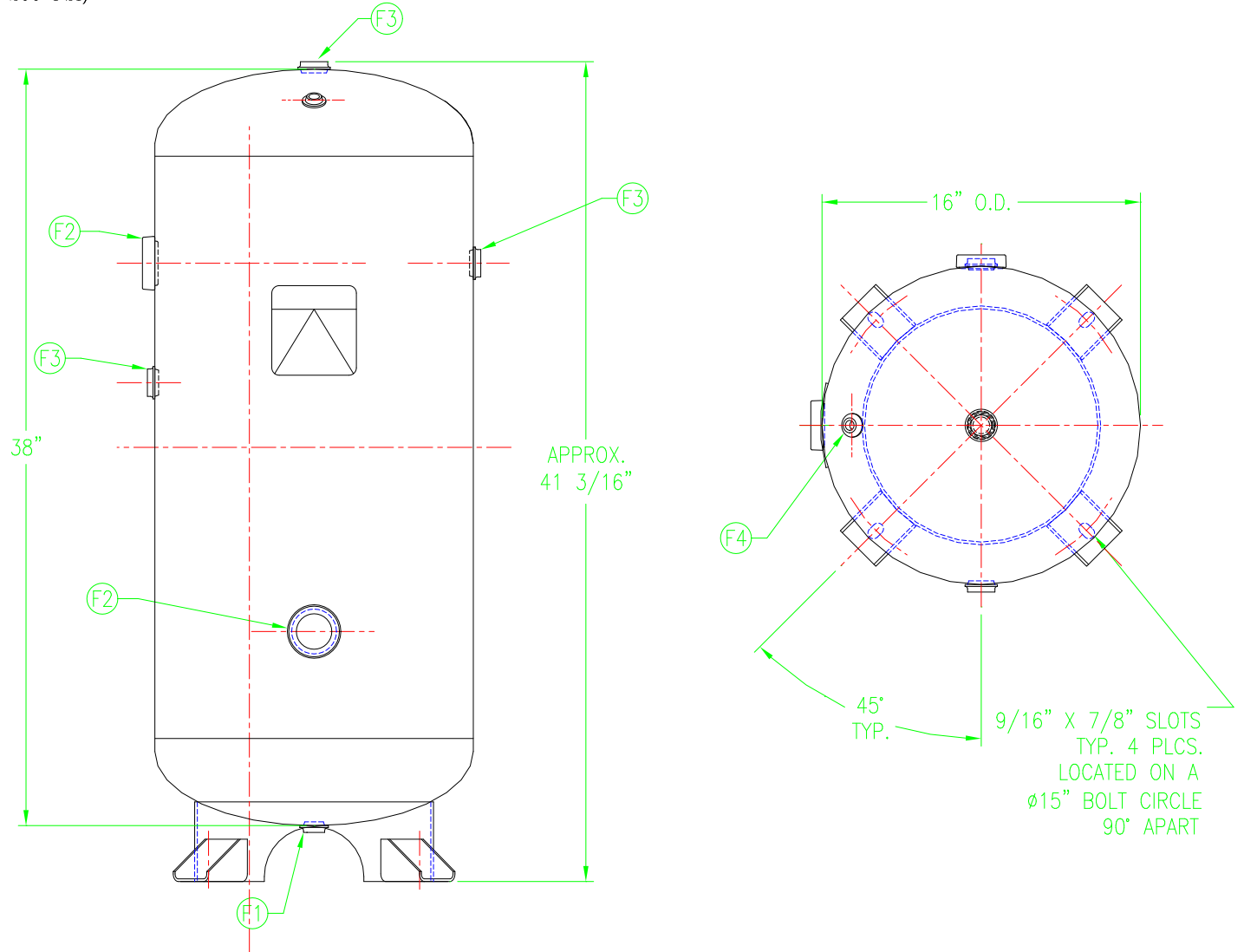

REVISIONS

REV	DESCRIPTION	DATE	CHK	ECN #

OGSI
 814 Wurliizer Drive
 North Tonawanda, NY 14120
 Phone: (716) 564-5165
 Fax: (716) 564-5173

FILE NAME
 AST_OST-30
 GEN ARR.

PLOT SCALE
 1 TO 1
 ENGINEER
 J. M. McMAHON

EFFECTIVITY OR SERIAL NO.
 DRAWN BY
 V.CAULEY
 DATE
 08/19/09
 PAGE
 1 OF 1

TITLE
 GENERAL
 ARRANGEMENT
 AST_OST-30