



MINING

*Increase Recovery
in Your
Merrill Crowe
Separation
Process
up to 99.7%*



Boost gold recovery and reduce your mine's operating costs
- Take oxygen directly from the air...

Increase the level of dissolved oxygen in your mine's leaching process without the expense and trouble of liquid oxygen purchases. Oxygen Generating Systems Intl. designs, builds, and installs turn-key industrial PSA oxygen systems worldwide. Our equipment is fully automatic, easy to maintain, and produces a continuous flow of oxygen directly to your leaching tanks. *These systems are ideal for gold and copper mining operations.*

The introduction of pure oxygen into the leaching process
increases your bottom line in four important ways:

Increased Gold Recovery

An increase in the dissolved oxygen level of gold bearing slurry enhances the gold cyanidation process. Mines operating at 98.5% recovery rates can expect a full percentage increase by boosting dissolved oxygen levels above 20 ppm. Mines operating below 98.5% recovery can expect even greater improvement.

Increased Silver Recovery

Mines operating at 93% recovery of silver bearing slurry can increase silver recovery up to 3%. In areas where silver concentration is great, the value of recovered mineral can be significant.

Decreased Cyanide Costs

The cyanidation process depends on the reaction of gold, cyanide, water and oxygen in the slurry. When the dissolved oxygen concentration is increased, the amount of cyanide required can be decreased as much as 25%.

Decreased Waste Treatment Costs

A portion of the oxygen generated can be routed through an ozone generator, and injected directly into the waste stream as an environmentally friendly oxidizing agent. A reduction in the amount of cyanide needed in the leaching process decreases the amount of cyanide that must eventually be removed from the waste stream.

APPLICATION NOTE
 Oxygen Generating Systems Intl.

1-800-414-OGSI • 716-564-5165
 6474

www.ogsi.com

Investing in an OGSi oxygen generator is the best way to introduce oxygen into your slurry leaching and cyanide decontamination systems.

Economy: A modest capital investment in an OGSi system can pay for itself within months. Our generators average only 3 kilowatts of electricity per 100 cubic feet of oxygen produced.

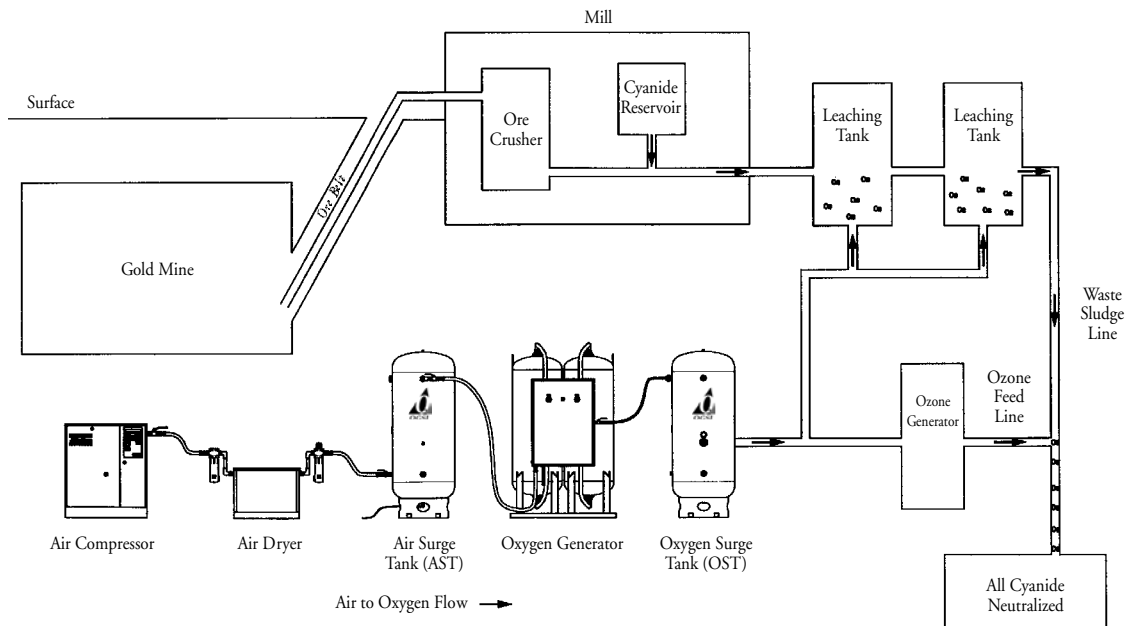

Autonomy: An on-site oxygen generator is the best way to eliminate dangerous, expensive, and unreliable deliveries of liquid or cylinder oxygen. OGSi oxygen generators can be operated and maintained without extensive technical knowledge or training. Easy to follow manuals, videos, and on-site training will enable your crew to properly calibrate and maintain the system. Routine maintenance is limited to normal air compressor upkeep and periodic cleaning/replacement of air filter elements.

OGSi Equipment Operating in Over 70 Countries

With our worldwide base of installed equipment, OGSi has the engineering and manufacturing experience to meet your facility's needs. Our sales and service network is dedicated to keeping your oxygen generator system in top condition.



814 Wurlitzer Drive • North Tonawanda, New York 14120 USA
 1-800-414-**OGSI**(6474) • Phone 716/564-5165 • Fax 716/564-5173
 A Division of Novair **NOVAIR**
 www.ogsi.com